

**This instruction manual concerns the OM 22 and OM 24 units
having the software version > E.00**

1. INTRODUCTION	3	5.5	SELECTING OPERATING MODES	10
2. CHARACTERISTICS	3	5.5.1	4-wires principle	10
2.1 APPLICABLE STANDARDS	3	5.5.2	Selecting measurement current	11
2.1.1 Safety class	3	5.5.3	Selecting the range	11
2.1.2 EMC conformity	3	5.5.4	Selecting current waveform	11
2.1.3 Environmental conditions	3	5.6	MEASUREMENT CYCLE	12
2.1.4 Mechanical conditions	3	5.6.1	STANDBY position	12
2.1.5 Reference measurement conditions	3	5.6.2	OPER command	12
2.1.6 Resistance measurements	3	5.6.3	HOLD position	12
2.1.7 IEEE-488 interface	3	5.6.4	External trigger command	12
2.1.8 RS 232-D interface	3	5.6.5	Operating diagrams	12
2.2 GENERAL SPECIFICATIONS	3	5.7	OTHER FUNCTIONS	13
2.3 PARTICULAR SPECIFICATIONS	4	5.7.1	Relative measurement (AR)	13
2.3.1 General conditions	4	5.7.2	Relative measurement (AR / R)	13
2.3.2 Ranges	4	5.7.3	Analog limits (clamping)	13
2.3.3 Accuracy	4	5.7.4	Alarms	13
2.3.4 Additional specifications	4	5.7.5	Temperature compensation	13
2.3.5 Other specifications	5	5.7.6	Heating measurement	14
		5.7.7	Resistance per unit length measurement	14
		5.8	MEASUREMENT MEMORY	14
		5.8.1	Immediate measurement clearing	15
3. MEASUREMENT ACCESSORIES	5	6. IEEE-488 AND RS 232 INTERFACES	16	
3.1 DELIVERED WITH THE UNIT	5	6.1 INTRODUCTION	16	
3.2 OPTIONAL ACCESSORIES	5	6.2 SYNTAX	16	
4. INSTRUCTIONS BEFORE USE	6	6.2.1 Command messages	16	
4.1 UNPACKING	6	6.2.2 Response messages	16	
4.2 RETURN	6	6.2.3 Detecting remote control errors	17	
4.3 INSTRUCTIONS BEFORE SWITCHING ON	6	6.2.4 Instrument registers, service request	17	
4.4 CONTROLS	6	6.2.5 Input buffer	18	
4.4.1 Front panel	6	6.2.6 Output buffer	18	
4.4.2 Rear panel	6	6.2.7 Exception procedures	19	
4.4.3 Tilt handle position	6	6.2.8 Sequential and overlapped commands,		
4.5 PANEL OR RACK MOUNTING	7	commands		
4.5.1 Panel cut-out	7	ignored in local	19	
4.5.2 Panel mounting	7	6.3 UNIT REMOTE COMMANDS	19	
4.6 CONNECTIONS	7	6.3.1 Commands defined by IEEE-488.2	19	
4.6.1 Internal current source	7	standard	19	
4.6.2 OM 22/OM 24 external current source	8	6.3.2 Specific RS-232 mode commands	20	
4.6.3 Temperature probe	8	6.3.3 Commands affecting the unit specific	20	
4.6.4 Trigger command	8	registers	20	
4.6.5 Safety terminal	8	6.3.4 Commands affecting working		
4.6.6 Analog output	8	characteristics	20	
4.6.7 Alarm outputs	8	6.3.5 Commands affecting the measurement		
4.6.8 RS 232 plug	8	cycle	21	
4.6.9 3 V, 10 A external source for OM 22	8	6.3.6 Commands affecting other functions	22	
5. OPERATION	9	6.3.7 Configuration commands	24	
5.1 SAFETY INSTRUCTIONS	9	6.3.8 Commands affecting the burst memory	24	
5.1.1 Safety standards compliance	9	6.3.9 Error commands	27	
5.1.2 Following the instructions supplied		7. MAINTENANCE	27	
with the		7.1 OPENING THE UPPER AND LOWER COVERS	27	
accompanying documents	9	7.2 CLOSING THE CASE	27	
5.1.3 Making measurements	9	7.3 REPLACING FUSES	27	
5.1.4 Faults and abnormal forces	9	7.3.1 Power fuse	27	
5.1.5 Definitions	9	7.3.2 Current circuit fuse	28	
5.1.6 Maintenance	9	7.4 POWER SUPPLY 230 V OR 115 V	28	
5.2 SWITCHING ON	10	7.5 SERVICING THE BATTERY PACK (OM 22)	28	
5.3 ERROR MESSAGES	10	7.5.1 Normal usage	28	
5.3.1 Display	10	7.5.2 Storage	28	
5.3.2 Audible warning (beep)	10	7.5.3 Replacing the battery pack	28	
5.4 SELECTING OPERATING CONFIGURATION	10	7.6 EXTERNAL POWER SUPPLY (OM 22)	28	
		7.7 PERFORMANCE VERIFICATION	28	
		8. WARRANTY	29	
		DECLARATION OF CONFORMITY	30	

Short operating mode

You have just received the unit and two alternatives may appear:

1)- The unit is not configured and you have to do it as explained in the instruction manual by programming the parameters satisfying to your own criteria and by assigning them to one of the six configuration keys numbered from 1 to 6. A blank sheet located at the end of the manual enables you to note the different configurations chosen.

2)- The unit is configured in our works according to your own criteria and the sheet located at the end of the manual resumes the different configurations.

From this moment, the unit is quite easy to use:

- press the **I/O** key and if required the \star key to light the display,
- press one of the six keys numbered from **1** to **6** which corresponds to the desired configuration,
- press the **OPER** key to start the measurements,
- press the **STBY** key to return to standby position,
- if the selected configuration includes storage of measurements, press the **CM** key if you wish to clear the last memorized measurement,
- and, for a heating measurement, refer to the instruction manual, paragraph 5.7.6, page 14.

1. Introduction

The OM 22 and OM 24 are versatile micro-ohmmeters, combining high resolution and accuracy with ease of use. They measure from $0.1 \mu\Omega$ à $26 \text{ k}\Omega$ (OM 22) and from $1 \mu\Omega$ to $260 \text{ k}\Omega$ (OM 24) with an accuracy of 0.03 %.

Main applications:

- contact resistance measurement with or without voltage limits (20 mV or 50 mV),
- ground continuity and cable resistance measurements,
- inductive resistance measurements in transformers, alternators, etc.,
- quotient measurements using a current source and external resistance standard.

The design features two microprocessors, offering the following advantages:

- automatic calibration with no internal adjustments needed,
- automatic compensation for stray e.m.f.,
- measurement control and processing via RS 232-D (standard) or IEEE-488 (optional) interfaces.

The OM 22 can operate from an optional built-in battery pack with charger.

The different versions are as follows:

- OM 22-1: Basic model (mains supply and RS 232).
- OM 22-2: Basic model with battery and charger.
- OM 22-3: Basic model with IEEE-488 interface.
- OM 22-4: Basic model with battery, charger and IEEE-488 bus.
- OM 24-1: Basic model.
- OM 24-3: Basic model with IEEE-488 bus.

2. Characteristics

2.1 APPLICABLE STANDARDS

2.1.1 Safety class

In accordance with European Norm EN 61010-1. Category III, pollution 2. Rated voltage: 50 V.

Note: applicable safety instructions can be found in paragraph 5.1.

2.1.2 EMC conformity

The unit performances meet the standards following:
Conducted and radiated disturbances: EN 55022/1994, class B.
Immunity: EN 50082-1/1992
Radiated: IEC 801-3/1984. Conducted: IEC 801-4/1988.
Electrostatic discharges: IEC 801-2/1991.

2.1.3 Environmental conditions

In accordance with IEC Publication 359 (national standards NF C 42-600, DIN 43745): operating category I. Reference range: $23^{\circ}\text{C} \pm 1^{\circ}\text{C}$, relative humidity: 45 % to 75 %. Normal operating mode: 0°C to $+ 50^{\circ}\text{C}$, relative humidity: 20 % to 80 % non-condensing. Operating range limits: - 10°C to $+ 50^{\circ}\text{C}$, relative humidity: 10 % to 80 % non-condensing. Limits for storage and transport: - 30°C to $+ 55^{\circ}\text{C}$ (- 15°C to $+ 50^{\circ}\text{C}$ for model with battery).

2.1.4 Mechanical conditions

Protection according to IEC Publication 529 (national standard NF C 20-010): IP 40. Vibrations: according to IEC Publication 68-2-6. Shocks according to European Norm EN 61010-1.

2.1.5 Reference measurement conditions

In accordance with IEC Publications 359 and 485 (national standards NF C 42-630 and DIN 43751).

2.1.6 Resistance measurements

Electrical continuity and contact resistance: tests in accordance with IEC Publication 512-2, DIN 41640 Ch. 4. Ground continuity: in accordance with GAM-EG13, ch. 61.

2.1.7 IEEE-488 interface

In accordance with IEC Publications 625-1 and 625-2 (national standards NF C 42-910 and NF C 42-911, DIN IEC 625-1 and DIN IEC 625-2) and American standard IEEE-488.2.

2.1.8 RS 232-D interface

In accordance with ANSI EIA-232-D-1986 standard.

2.2 GENERAL SPECIFICATIONS

- 11-key pad covering all operating functions.
- The RS 232-D or IEEE-488 interfaces allow programming (6 memorized programs), measurement processing and unit calibration from a computer as well as measurement output to a printer.
- Languages available: English, French, German, Spanish, Italian.
- Audible warning (beep) of any incorrect operation. Display of error messages in case of overload, overrange or incorrect connections.
- Measurement terminals duplicated on rear for rack mount operation.
- Alphanumeric liquid crystal display with built-in lighting.
- Direct reading of measurement and units: $\mu\Omega$, $\text{m}\Omega$, Ω , $\text{k}\Omega$, %, $^{\circ}\text{C}$.
- 18 measurement ranges as described in paragraph 2.3.
- Selectable measurement current:
OM 22: from $100 \mu\text{A}$ to 10 A, supplied by a built-in Ni-Cd battery 2.6 V, 1.8 Ah, automatically recharged depending on its state.
OM 24: from $10 \mu\text{A}$ to 1 A.
- Automatic or manual range selection according to measurement voltage (fixed current).
- Three operating modes:
 - . direct current (except with 10 A range),
 - . pulse current,
 - . alternate current (current flow inversion).
- Relative mode value read-out (ΔR or $\Delta R/R$).
- Programming directly by metal type or by temperature coefficient offers the following advantages:
 - . automatic heat measurement of the component under test,
 - . automatic compensation of its temperature, either by program or by measurement using platinum probe.
- Measurement storage on request (1 000 values max.) with min., max. and average values sent to the interfaces.
- Power requirements:
 $230 \text{ V} \pm 10 \%$, 50-400 Hz ($240 \text{ V} + 6 \%$, - 10 % permissible).
 $115 \text{ V} \pm 10 \%$, 50-400 Hz by internal switch.
Consumption: 20 VA max.
Optional battery pack and charger for the OM 22 model.

- Dimensions: 225 mm x 88 mm x 310 mm (overall width: 275 mm with handle/support).

- Weight: 2 kg (3 kg max. with battery and optional IEEE-488).

2.3 PARTICULAR SPECIFICATIONS

2.3.1 General conditions

Stated accuracies are expressed in $\pm (n \% \text{rdg} + C)$ with
rdg = reading and C = constant expressed either as a practical unit, or a number of Representation Unit (RU), i.e. the number of units of the last digit.

They apply to instruments in the reference conditions defined elsewhere after warming up for one hour.

2.3.2 Ranges

2.3.2.1 Internal current

OM 22

Range	Reso- lution	Rated voltage drop					
		Measurement current					
		10 A	1 A	100 mA	10 mA	1 mA	100 μ A
2.0 m Ω	0.1 $\mu\Omega$	20 mV					
20 m Ω	1 $\mu\Omega$	200 mV	20 mV				
200 m Ω	10 $\mu\Omega$	2 V	200 mV	20 mV			
2.0 Ω	100 $\mu\Omega$		2 V	200 mV	20 mV		
20 Ω	1 m Ω			2 V	200 mV	20 mV	
200 Ω	10 m Ω				2 V	200 mV	20 mV
2.0 k Ω	100 m Ω					2 V	200 mV
20 k Ω	1 Ω						2 V

OM 24

Range	Reso- lution	Rated voltage drop					
		Measurement current					
		1 A	100 mA	10 mA	1 mA	100 μ A	10 μ A
20 m Ω	1 $\mu\Omega$	20 mV					
200 m Ω	10 $\mu\Omega$	200 mV	20 mV				
2.0 Ω	100 $\mu\Omega$	2 V	200 mV	20 mV			
20 Ω	1 m Ω		2 V	200 mV	20 mV		
200 Ω	10 m Ω			2 V	200 mV	20 mV	
2.0 k Ω	100 m Ω				2 V	200 mV	20 mV
20 k Ω	1 Ω					2 V	200 mV
200 k Ω	10 Ω						2 V

Measurement max. capacity: 26 000 counts.

For the OM 22, this value depends on the accumulator charge supplying the current source, the resistance of connection wires (especially for ranges using 1 A and 10 A currents) and the rated voltage drop 2 V.

Max. open circuit voltage: 3 V, (can be limited to 20 mV or 50 mV at the terminals of the resistor to be measured).

2.3.2.2 External current

Rated range	Rated voltage drop	
	I * Rref = 1.0 V \pm 20 %	I * Rref = 0.1 V \pm 20 %
0.02 Rref \varnothing	20 mV	
0.2 Rref	200 mV	20 mV
2 Rref	2 V	200 mV
20 Rref		2 V

\varnothing Rref = value of the reference resistor.

2.3.3 Accuracy

Rated voltage drop	External	Measurement current	
		10 and 1 A	from 0.01 to 100 mA
20 mV	0.05 % + 5	0.05 % + 3	0.03 % + 3
200 mV	0.05 % + 3	0.05 % + 2	0.03 % + 2
2.0 V	0.05 % + 1	0.05 % + 1	0.03 % + 1

Temperature coefficient: < 10 % of accuracy/ $^{\circ}$ C.

2.3.4 Additional specifications

- Protection: a fast electronic circuit protects against current break in an inductive resistor.

- Min. interval between measurements:
. 500 ms in direct current mode,
. 2 s in pulse current mode,
. 3 s in alternate current mode.

- Manual or automatic measurement rate programmable from two measurements per second to one per 32 400 seconds (9 hours).

- Autoranging (fixed current):
. by increasing values: > 21 000 RU,
. by decreasing values: < 2 000 RU.

- Relative measurements

The unit displays:

. either $L = R - R_0 (\Delta R)$,
. or $L = 100 (R - R_0) / R_0$ in % ($\Delta R/R$),

where:

L = value read,
R = value measured in the range selected,
R0 = reference value which is either a value stored or a programmed fixed value.

- Automatic component temperature compensation:
. from - 20 $^{\circ}$ C to + 130 $^{\circ}$ C programmed via the interfaces by means of a platinum probe (100 Ω at 0 $^{\circ}$ C) available as an option.

Accuracy: \pm 0.5 $^{\circ}$ C.

- Analog output:

. 0 to 2.55 V on load > 2.5 k Ω ,
. resolution 10 mV (256 counts),
. interface programming of values displayed for 0 V and 2.50 V,
. accuracy: \pm 10 mV,
. response time: according to measurement.

Note: values stored in the measurement memory can be converted into analog signals for plotter output.

- Double digital comparator providing two relay alarm outputs (one NO contact, 1 A~, 125 V~, 30 W, 60 VA max.) programmed by limits, direction and hysteresis.

- Current source autonomy (OM 22):
10 A pulse current, min. interval: 2 hours.
1 A direct current: 2 hours.

2.3.5 Other specifications

2.3.5.1 Trigger command

Triggering measurement burst remotely (paragraph 5.6.4) can be done by short-circuiting two terminals at back of the unit and using an external uncharged contact (dry contact or semiconductor: 5 V, 0.1 mA).

2.3.5.2 Battery operation (OM 22)

The unit can work from the 12 V lead battery pack supplied with internal charger.

Life: 2 h to 8 h depending on mode and current value selected.

Charging time: 14 hours for a fully discharged battery.

When the remaining charge reaches approximately 20 %, the **BAT** symbol advises the user to recharge the battery.

To avoid any damage, an electronic device provides automatic disconnection of the battery in case of prolonged discharge. In this case, the unit stops operating and an immediate recharge is necessary.

2.3.5.3 RS 232-D interface

Available at rear of the unit on a 9-pin SUB-D female connector.

Interface specifications:

- Transmission rate: 300, 600, 1 200, 2 400, 4 800, 9 600, 19 200 bauds.
- Character format: 7 or 8 bits with 1 or 2 stop bits.
- Parity: even, odd, ignore or no parity.
- Protocol: no protocol, XON/XOFF, CTS/DTR or printer.
- In printer mode, selection of the column numbers for table display (11 characters per measurement, two spaces between successive measurements).

These parameters are programmed via the interfaces and stored in battery backed memory.

Refer to chapter 6 for full details.

2.3.5.4 IEEE-488.2 interface

Available on a standard 24-pin plug.

The address of the unit is entered via the interfaces and stored in battery backed memory.

Both IEEE and RS 232 circuits are set to the same potential as the trigger command.

Available functions:

AH1 SH1 T6 L4 SR1 RL1 PP0 DC1 DT0 C0 E2

Refer to chapter 6 for full details.

3. Measurement accessories

3.1 DELIVERED WITH THE UNIT

- A power cord.
- An instruction manual.

3.2 OPTIONAL ACCESSORIES

AN 5806-B	A pair of security measurement leads, each with a Kelvin clip, 1.20 m of wire and two 4 mm plugs
AMT 004	One measurement lead, 3 m long, with a large Kelvin clip.
AMT 003	One measurement lead, 3 m long, with a dual Kelvin test probe.
AN 5825	Set of 10 spare fuses. (5 x 20, T 160 mA/250 V).
AN 8009 (OM 22)	Set of 10 spare fuses. (6.3 x 32, F 16 A/250 V).
AN 5826 (OM 24)	Set of 10 spare fuses. (6.3 x 32, F 2 A/380 V).
ER 42062-001	Protection network for alarm relay contact.
ER 48289-009	9-pin male SUB-D connector for the RS plug.
AN 5874	RS 232-D cable, 2 m long, for connection to a microcomputer (PC-XT, PC-AT or compatible) equipped with 25-pin male SUB-D connector.
AN 5875	RS 232-D cable, 2 m long, for connection to a microcomputer (PC-XT, PC-AT or compatible) equipped with 9-pin male SUB-D connector.
AN 5876	RS 232-D cable, 2 m long, for connection to a printer equipped with 25-pin female SUB-D connector.
AN 5893	RS 232-D cable, 5 m long, for connection to a printer equipped with 25-pin female SUB-D connector.
AN 5836	IEEE-488 cable, 2 m long.
LM 105	Software for programming and processing measurements on microcomputer (PC-XT, PC-AT or compatible) via the RS 232-D interface.
Platinum probes	Different models depending on usage: please, contact us.
AN 5883	Brackets for panel mounting.
AN 5884	3 U panel and brackets for rack mounting.
AMT 002-000	3 V, 10 A bench-type supply to replace the current source accumulators.
AN 6901	Carrying case.

4. Instructions before use

4.1 UNPACKING

The unit is mechanically and electrically checked before dispatch. Every precaution is taken to ensure that it reaches the user undamaged.

Nevertheless, it is advisable to carry out a quick check for any damage that may have occurred in transit. If any such damage is found it should be reported to the shipper.

4.2 RETURN

If the unit is to be returned, the original packaging should be used and a note explaining as clearly as possible the reasons for returning it should be included.

4.3 INSTRUCTIONS BEFORE SWITCHING ON

Before using the unit with all the necessary safety, the user must read **carefully** chapter 5 which deals with safety provisions.

4.4 CONTROLS

4.4.1 Front panel

(Example: OM 22)

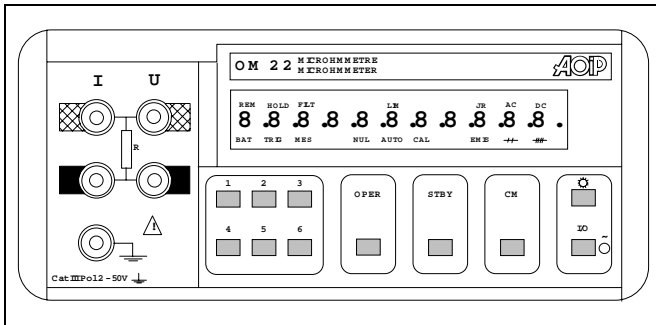

Liquid crystal display

- 11 characters, 11.5 mm high, indicating value, unit, range and operating mode.
- To the left, one function symbol **REM** (remote), one battery state **BAT**, and three measurement operating symbols **TRIG**, **MES**, **HOLD**.
- In the middle, the autorange symbol **AUTO**, the symbol **NUL** when measuring ΔR or $\Delta R/R$ and one **LIM** symbol indicating if 20 mV or 50 mV limit is in use.
- To the right, the **-//-** symbol indicating that temperature compensation is in use (measurement reduced to 20°C) and the **-////-** symbol when running the heating measurement cycle of a component.

Terminals

Five terminals for 4 mm plugs:

- 2 terminals **I** supplying the preselected measurement current.
- 2 terminals **U** to input the voltage from the resistor terminals.
- 1 ground terminal internally connected to the earth wire of the power cord.

Keypad

11-key keypad and one mains indicator.

► Operating configuration keys

Six keys, from 1 to 6, select one of the six possible configurations programmed via the RS 232-D or IEEE-488 interfaces.

► Operating mode keys

- OPER** Operation. Starts a measurement cycle.
- STBY** Standby.
- CM** Clears the last measurement from memory.
- ★ Switches display lighting ON or OFF.
- I/O** Switches the unit ON or OFF.

4.4.2 Rear panel

(Example: OM 22)

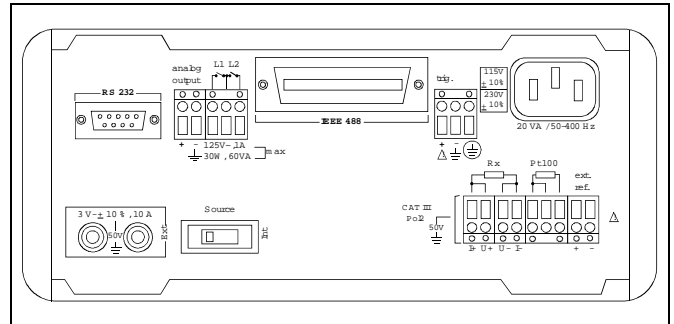

From left to right:

- 9-pin female RS 232 connector (see paragraph 4.6.8).
- 4 mm input sockets for the 3 V \pm 10 %, 10 A source (OM 22 only, see paragraph 4.6.9).
- The internal/external source switch (OM 22 only, see paragraph 4.6.9).
- Terminal board to connect the analog output and alarm outputs (see paragraphs 4.6.6 and 4.6.7),
- Optional IEEE-488 connector (see chapter 6).
- Trigger command (see paragraph 4.6.4).
-  terminal for connection to a safety conductor when the unit is battery operated (see paragraph 4.6.5).
- Plug for power cord.
- Terminal block: 4 terminals are used to connect the resistor to be measured, 3 for the platinum probe (temperature compensation) and 2 for the reference voltage when using the external I connection (see paragraphs 4.6.1 to 4.6.3),

4.4.3 Tilt handle position

To change the position of the handle:

- press the two yellow knobs and turn the handle,
- release the knobs and turn the handle until it locks into position. The angle between each position is 30°.

4.5 PANEL OR RACK MOUNTING

Panel or rack mounting is done with right-angle brackets in the AN 5883 optional kit.

The accessory AN 5884 is used for the 3 U rack mounting and also includes these right-angle brackets.

4.5.1 Panel cut-out

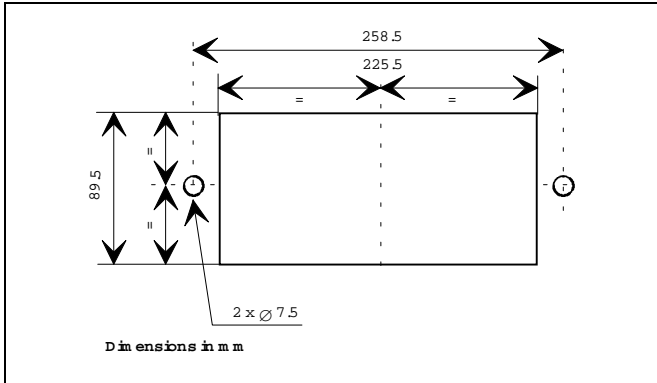

4.5.2 Panel mounting

- Remove the handle by unscrewing four screws.
- Use the four holes to fix two right-angle brackets with 4 countersunk-head screws.
- Insert the unit through the panel cut-out and fix it by using two M6 screws.

4.6 CONNECTIONS

4.6.1 Internal current source

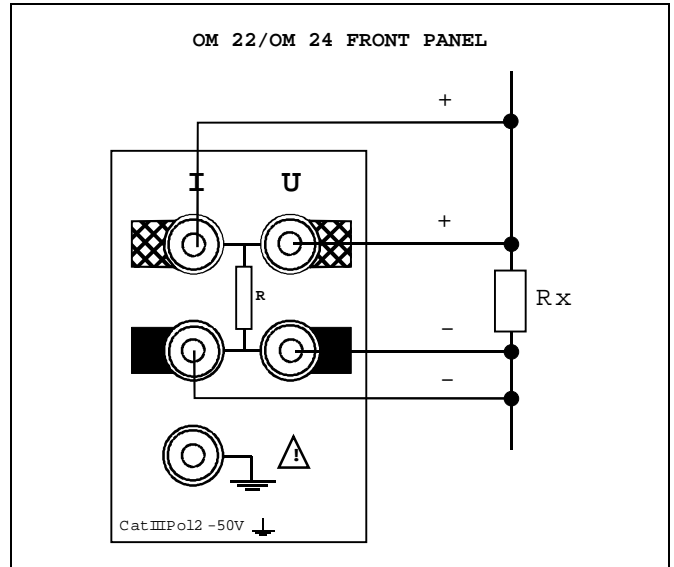

or

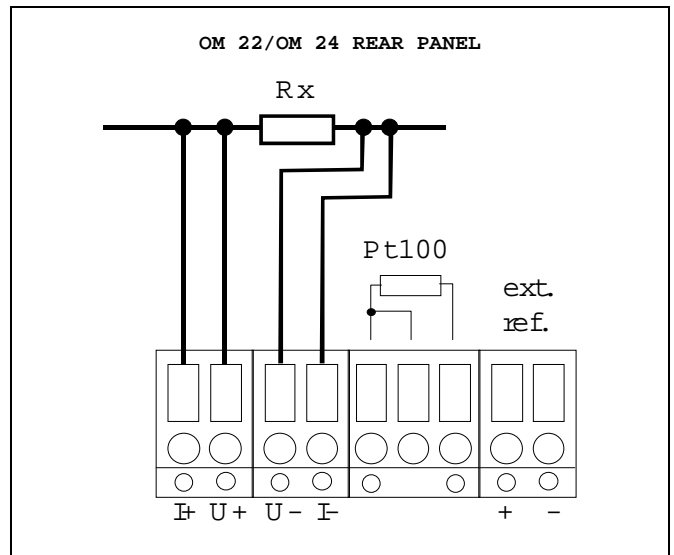

4.6.2 OM 22/OM 24 external current source

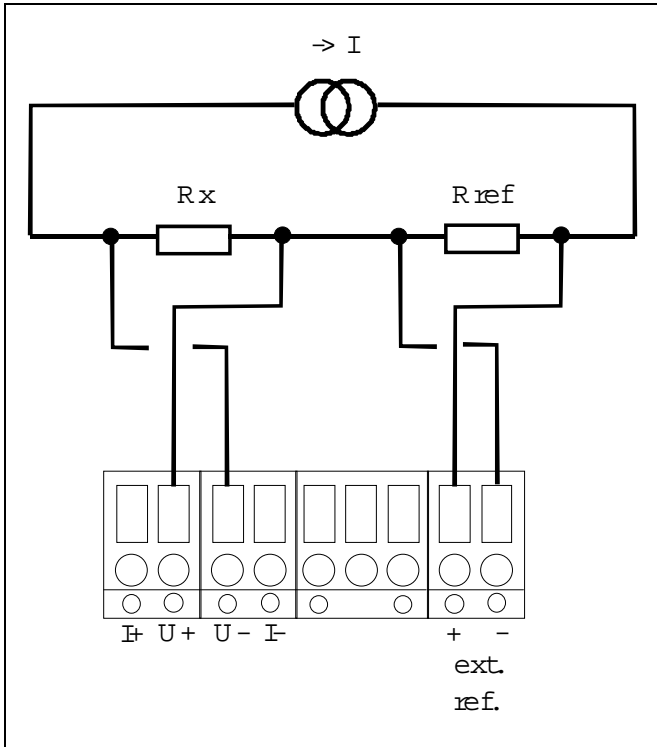

4.6.3 Temperature probe

Connect the probe to the **Pt100** terminals as indicated at back of the unit.

The "common" wire (left terminal) is set to potential of **I -**.

Using 3 wires to connect the probe, make sure the resistance is balanced: 50 Ω max. permissible.

4.6.4 Trigger command

Connect the **décl. trig.** terminals at rear to an external uncharged NO contact: dry contact or semiconductor.

If using semiconductor, respect the polarities indicated (internal source 5 V, 47 kΩ).

The \perp negative terminal is connected to the protection earth.

4.6.5 Safety terminal

This \perp terminal near the trigger command is internally connected to the front ground terminal and to the earth wire of the power cord.

It can be used when the unit is panel-mounted and operates from the rear terminals and/or when the unit is battery-operated, without power cord, and needs to be connected to earth.

4.6.6 Analog output

Connect the **analog output + -** at rear to an instrument, range ≥ 2.5 V (voltmeter, recorder, etc.).

The \perp negative terminal is connected to the protection earth.

4.6.7 Alarm outputs

Connect the **L1 L2** terminals at back as indicated.

These terminals are free from any potential.

For inductive loads, it is advisable to set protection networks to their terminals by using the ER 42062-001 optional accessory (see paragraph 3.2).

4.6.8 RS 232 plug

Use a 9-pin male SUB-D connector (ER 48289-009 optional accessory) or one of the following optional cables:

- AN 5874** for computer equipped with a 25-pin male SUB-D connector
- AN 5875** for computer equipped with a 9-pin male SUB-D connector.
- AN 5876** for printer equipped with a 25-pin female SUB-D connector.

Connections are as follows:

OM side male connector 9 pins	Link	Computer side female connector		Printer male connector 25 pins
		25 pins AN 5874	9 pins AN 5875	AN 5876/5893
CD 1	→	8	1	
RD 2	→	3	2	3
TD 3	←	2	3	2
DTR 4	←	20	4	20
Com 5	—	7	5	7
DSR 6	→	6	6	
RTS 7	←	4	7	
CTS 8	→	5	8	5
RI 9	→	22	9	

NOTE:

- RS-232 circuits are set to the potential of the trigger command, IEEE circuits and analog output.
- Upon receiving the unit, pin 5 (Common) is connected to the ground.
- Pins 1, 7 and 9 are free from any potential on OM side.
- Line DSR is permanently set to 1 (+ 9 V).
- **Always wire the wires at printer level as a minimum.**

4.6.9 3 V, 10 A external source for OM 22

For models OM 22-1 and OM 22-3 with mains supply and in case 1 A and 10 A currents are often used, it may be advisable, in order to avoid any autonomy problem due to the current source accumulators, to replace them by a 3 V- ± 10 %, 10 A external source (example: AMT 002-000).

For that, connect the supply outputs to the OM 22 - 3 V input using 4 mm leads and **follow the polarities**, then switch the unit to this operating mode (see maintenance, paragraph 7.6).

5. Operation

5.1 SAFETY INSTRUCTIONS

5.1.1 Safety standards compliance

This unit is constructed and tested according to European Norm EN 61010-1: safety rules for electronic measurement instruments.

This instruction manual contains information and advice users must follow to protect against electrical shock and to ensure reliability, maintaining the instrument in a satisfactory state of safety.

The unit may occasionally be exposed to temperatures between - 10°C and + 50°C without safety features being compromised.

Do use the power cord supplied with the unit and do connect it to a 3-pin plug including ground, meeting EEC 7 specifications.

5.1.2 Following the instructions supplied with the accompanying documents

The unit is constructed to operate under safety conditions if the instructions supplied with the accompanying documents are followed. Any usage, except those described, may reduce the safety of the operator and then, becomes dangerous and prohibited.

5.1.3 Making measurements

Never connect the unit to a live circuit.

When measuring resistances with a high inductive component (transformers, motors, etc.) **do press the STBY key to cut off current.**

The unit then discharges this inductance and displays the **WAIT** message.

Wires should be disconnected only when the message has disappeared and an audible warning (beep) has been heard.

5.1.4 Faults and abnormal forces

If there is any indication that the instrument safety has been compromised, it should be taken out of service and steps taken to prevent it being used inadvertently.

Safety may be compromised in any of the following cases:

- the instrument is visibly damaged,
- the instrument is no longer capable of making accurate measurements,
- the unit has been stored in unfavorable conditions,
- the instrument has been subject to severe stresses or shock during transport.

5.1.5 Definitions

5.1.5.1 Definition of the installation category

This is also called overvoltage category. It's the installation classification according to standardized limits for transient overvoltages (IEC Publication 664).

CAT III: Equipment of overvoltage category III is equipment in fixed installations and for cases where the reliability and the availability of the equipment is subject to special requirements. Examples of such equipment are switches in the fixed installation and equipment for industrial use with permanent connection to the fixed installation.

5.1.5.2 Table of the symbols used

Symbol	Description
~	Alternating current.
⋮	Direct current.
⎓	Direct and alternating current.
⏏	Measurement earth terminal.
⏏	Protective conductor terminal.
I	Power ON.
O	Power OFF.
□	Double insulation.
⚠	Risk of electric shock.
⚠	Warning: see the accompanying document.

5.1.6 Maintenance

Refer to chapter 7.

The unit should be reassembled as explained in the instruction manual. Any incomplete or bad reassemble may be dangerous for the safety of the operator.

The responsible body must check at regular time interval that all the components ensuring safety are not subject to wear and undertake all the necessary steps for preventive operations.

Before opening the case, make sure the instrument is disconnected from any dangerous voltage source and that no output signal is being generated.

Replacement fuses must be of the same type and rating (see paragraph 7.3).

The instrument should not be opened for adjustment, maintenance or repair when live unless absolutely essential, in which case the work should be carried out **only by appropriately qualified personnel aware of the risks involved.**

5.2 SWITCHING ON

Make sure that the mains voltage matches that indicated on the rear panel. Connect the power cord. The indicator "~" comes on confirming power to the instrument.

Note: Models with optional battery pack only require connection to the mains when the BAT symbol appears at the left of the display, indicating that the battery should be recharged. The unit can be used during charge.

Press I/O: the unit is powered up, performs an initialization and self-check procedure and says Hello. Then, during two seconds, it indicates which interface is in use RS-232 or IEEE with the address. During this period, pressing of one of the keys CM or OPER is as follows:

CM key:

- The unit displays RESET? during two seconds approximately. Pressing OPER during this period reprograms the 6 configuration keys to their initial state and clears the burst memory.
- The unit initial configuration is as follows:
 - . French language,
 - . current 100 μ A DC,
 - . range 20 k Ω ,
 - . continuous measurement, interval 1 second,
 - . alarms and burst memory not in use,
 - . IEEE address = 12,
 - . RS-232 interface in use together with the following parameters: rate 9 600 bauds, 8 bits, 1 stop bit, no parity, CTS/DTR mode.

OPER key:

- If the unit is equipped with the two interfaces (RS 232 and IEEE), it changes the interface in use (RS 232 -> IEEE or IEEE -> RS 232) and indicates the main parameters:
 - . IEEE: the address,
 - . RS-232: rate, number of bits, parity, number of stop bit, protocol, number of columns with the "printer" protocol.
- If the unit only has the RS-232, it indicates the parameters as indicated above.

Changing the interface or modifying the parameters can be done by sending commands onto the interface in use (see paragraph 6.3.7).

Then, the unit switches to **STANDBY** with the configuration preceding the last stop.

5.3 ERROR MESSAGES

During operation, most errors are displayed with an audible warning (beep).

5.3.1 Display

OVERLOAD	Abnormal voltage on input circuits.
OVERRANGE	Measurement exceeds max. value over range selected (manual range) or over highest range for a given current (autorange).
CURRENT < 1A	Select a measurement current below 1 A and wait for a sufficient recharging of the accumulators powering the current source (LO BAT symbol blinks during this recharge).
(U) OPEN	Signals one wire broken in voltage connections after pressing OPER key when the unit was previously in standby.

(I) OPEN	Signals either opening of or too high resistance in current circuit when the unit is operating in pulse or alternate current mode.
CONNECT.ERR	Signals an incorrect connection, such as inversion of voltage wires compared to current wires.
CLAMPING	If one or both 20 mV or 50 mV analog limits are in use, indicates that voltage drop at terminals of the resistor to be measured is higher than this limit.
HIGH E.M.F	Indicates a too high offset voltage when measurement is made for automatic correction of external stray E.M.F.
PROBE ?	Signals absence or incorrect connection of the temperature probe.

These messages are accompanied by a beep.

5.3.2 Audible warning (beep)

A beep is emitted each time an operation cannot be taken into account.

5.4 SELECTING OPERATING CONFIGURATION

The keys from 1 to 6 allow the user to choose between 6 operating configurations previously programmed via the RS-232 or IEEE interfaces.

Selecting the different operating modes is explained here-after.

When pressing one of the configuration keys, the display indicates, on the left, the number of that configuration which corresponds to the key number, the range in use and occasionally the other functions programmed.

Then, the unit switches to **STANDBY** position.

5.5 SELECTING OPERATING MODES

5.5.1 4-wires principle

See diagram below:

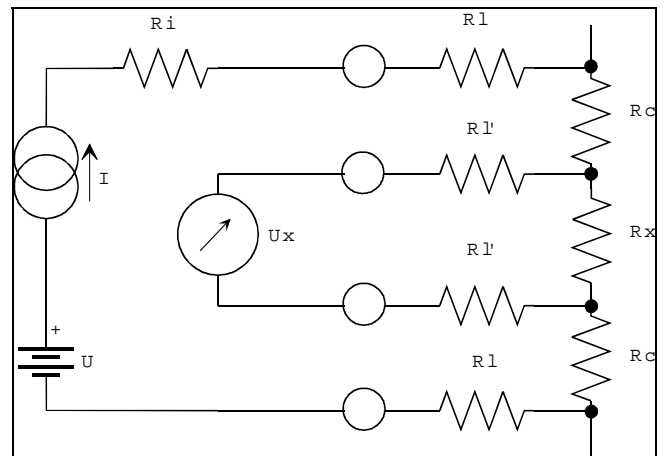

From a voltage source U , a generator supplies a current of value I and determined waveform (pulse, alternate or direct).

A voltmeter measures the voltage drop U_x at terminals of the resistor to be measured R_x and displays $R_x = U_x / I$.

The result is not affected by other resistors encountered in the current loop (R_x , R_l , R_c), as long as the total voltage drop induced across R_x remains below the voltage supplied by the source U .

For Rx defined by the range set, Ux squares with the measurement rated voltage for the measurement range selected.

To measure a resistance whose approximate value is known, the range table in para. 2.3.2 shows that the measurement can generally be performed with three different values of measurement current and rated voltage.

5.5.2 Selecting measurement current

The user can select 6 measurement currents: 10 μ A (OM 24), 100 μ A, 1 mA, 10 mA, 100 mA, 1 A, 10 A (OM 22), and use an external current source EXT.I

In external current mode, the range also depends on the programmed values specific to the this operating mode.

5.5.3 Selecting the range

For a previously set measurement current, the unit offers three measurement voltages (20 mV, 200 mV, 2 V), i.e. three ranges (range = V/I).



To change the range, the user may:

- use the autoranging by programming the AUTO mode, the same symbol appears on bottom of the display.
- force one of the three ranges by programming.

Note: Changing range does not change measurement current, so it is limited to three.

5.5.4 Selecting current waveform

Three current waveforms are available:

-  pulse current.
-  alternate current.
-  direct current.

5.5.4.1 Pulse current

This is the current mode generally used to measure low inductive resistances accurately (time constant below 1 ms).

Each measurement is performed as follows:

- switch current off, measure residual voltage (U0) at resistor terminals. If more than measurement rated voltage, HIGH E.M.F error is displayed,
- switch current on for 200 ms, compare to selected current, if wrong (I) OPEN error is displayed,
- measure voltage at resistor terminals (U1) and break current,
- display measurement (L = (U1 - U0) / I) or error: OVERRANGE, CONNECT. ERR, CLAMPING, etc.

Measurement duration: between 0.5 and 0.8 s depending on measured resistance value.

5.5.4.2 Alternate current

This the current mode recommended for measuring ground continuity or contact resistance and by storing, according to standards, the highest or average value in both current directions. As stated above, this mode only applies to low inductive resistors.

Each measurement is performed as follows:

- switch current off, measure residual voltage (U0) at resistor terminals. If more than measurement rated voltage, HIGH E.M.F error displayed,
- switch current on respecting terminal polarity for 200 ms, compare to selected current, if wrong, display (I) OPEN error message,
- measure voltage at resistor terminals (U1) and break current,
- switch current on inverting terminal polarity for 200 ms,
- measure voltage at resistor terminals (U2) and break current,
- compute both measurements: L1 = (U1 - U0) / I and L2 = (U0 - U2) / I,
- if there is no operating error and depending on selected program, display average value L = (L1 + L2) / 2, or max. value L1 or L2.

Measurement duration: between 0.8 and 1.4 s depending on measured resistance value.

5.5.4.3 Direct current

Because of the limited power of the internal current source and power dissipated inside the casing, only currents below 10 A can be measured.

This mode is designed to measure resistances featuring a high inductive component: transformers, motors, etc.

Remember that the charge (or discharge) time constant of an inductor S (in Henrys) loaded by a current I (in Amperes) under a voltage U (in volts) is t (in seconds) = S I / U.

With an OM and to simplify, take U = 2 V for charge and U = 1 V for discharge. This gives:

$$t_c = S I / 2.$$

$$t_d = S I.$$

In this case it is impossible to switch current on and off each time a measurement is performed.

From standby, a measurement cycle (see para. 5.6) starts as follows:

- switch current off, measure residual voltage (U0) at resistor terminals. **This value is displayed for a moment (in mV) and stored in the burst memory if the memory is in use.** If above the measurement rated voltage, display HIGH E.M.F.
- **switch current on and maintain as long as the unit does not return to standby**, by pressing either STBY or a configuration key,
- the user may program the time-delay authorizing the first measurement after the Time Of Charge (TOC) has elapsed.
- at the end of the Time Of Charge (TOC) programmed if the current is not completely settle, the measurement, unless it is incorrect, is displayed to follow evolution, **but an (*) symbol adds to the unit indicating that it is not stored, nor taken in account by any other active functions.**

- measure voltage at resistor terminals (U1) and display measurement $L = (U1 - U0) / I$,
- any following measurements display U1, U0 being stored in memory. So, in this current mode, it is advisable to work on a fixed range to perform the offset measurement with the same rated measurement voltage as the main measurement, or from the lower range if autoranging is selected.
- **for safety reasons, returning to standby via one of the commands indicated above, implies waiting for complete discharge. During this period, the unit displays WAIT and all hands should be kept away from connecting wires.**

Measurement duration: between 0.2 and 0.4 s depending on the measured resistance value.

5.5.4.4 External current (EXT.I)

Connection is as indicated in paragraph 4.6.2.

Because the unit cannot "control" this current, it automatically switches to direct current mode.

As the current cannot be switched off because the reference voltage would be lost, the following method is used to compensate for any offset voltage:

- connect as indicated in paragraph 4.6.2,
- open the external current circuit,
- **perform a measurement using any internal current in direct current mode and, if possible, use the intended voltage range or the 20 mV range,**
- switch to external current mode,
- close external current circuit,
- start measurement cycle.

The value of the external current I can be selected between 10 mA and a few hundred amperes, but the voltage drop ($V_{ref} = I * R_{ref}$) across terminals of the reference resistor must be chosen between $100 \text{ mV} \pm 20 \%$ and $1 \text{ V} \pm 20 \%$.

Using manual or automatic ranging, three measurement ranges are available:

- for $V_{ref} = 1 \text{ V}$: $0.02 R_{ref}$, $0.2 R_{ref}$, $2 R_{ref}$,
- for $V_{ref} = 100 \text{ mV}$: $0.2 R_{ref}$, $2 R_{ref}$, $20 R_{ref}$.

5.6 MEASUREMENT CYCLE

5.6.1 STANDBY position

The unit is set to standby:

- at switch on,
- by pressing **STBY**,
- by pressing one of the configuration keys.

This position:

- switches off the internal current source,
- short-circuits current terminals (I),
- waits for a change in operating characteristics, starting a measurement cycle either by pressing **OPER** key or the external trigger command, or the RS-232 link or IEEE bus.

5.6.2 OPER command

This command triggers a measurement cycle depending on the following parameters:

- Number of measurements **Nb**, programmable between 0 (permanent measurement) and 65 535.
- Delay **DEL** between command and first measurement (measuring the offset voltage in all current waveforms) programmable between 0 and 32 400 s (9 hours).
- In **direct current** mode, the Time Of Charge **TOC** between current settling and first measurement.
- Interval **INT** between two consecutive measurements, programmable between 0.5 s and 32 400 s.

In view of the typical duration of a measurement cycle in pulse or alternate mode (see paragraph 5.5), an interval of 0.5 s between two measurements is not realistic and the unit defaults to a rate compatible with each operating mode.

Programming 0 s for the **DEL**ay increases it of 0.5 s when starting cycle from the "standby position", while from the "hold" position, it remains to 0.

5.6.3 HOLD position

Once the last measurement has been completed, the unit remains in a hold position which is different from the standby position in direct current mode in that measurement current remains present at the outputs (I).

In **direct current** mode, a new **OPER** command triggers another measurement cycle **without offset**.

So, in direct current mode, to measure the offset voltage again (e.g. after changing range), it is first necessary to switch to standby position.

5.6.4 External trigger command

Same function as the **OPER** key.

This command operates each time the **décl. trig.** terminals at back of the unit are short-circuited (see paragraphs 4.4.2 and 4.6.4).

5.6.5 Operating diagrams

Below, are the operating diagrams of the three current modes from standby position and **Nb** = 3 measurements.

pulse current

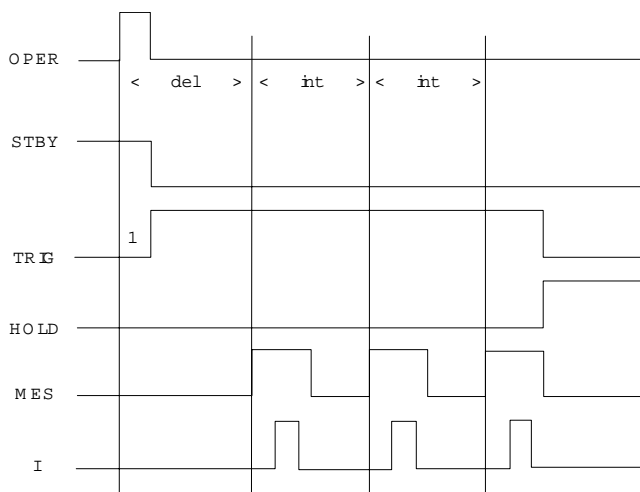

1: testing voltage wires (U) and first ambient temperature measurement if requested.

alternate current

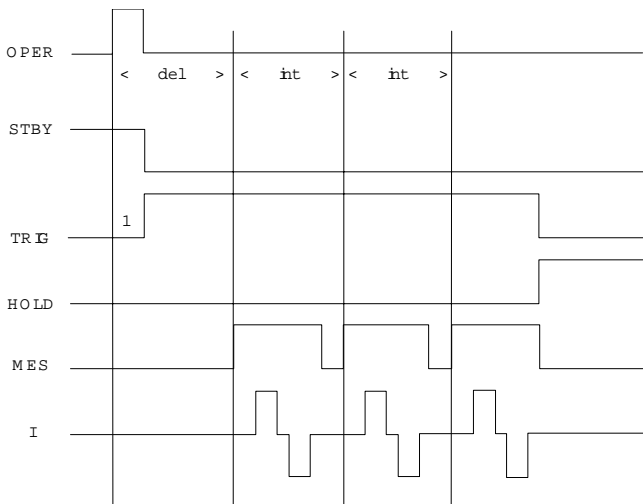

1: testing voltage wires (U) and first ambient temperature measurement if requested.

direct current

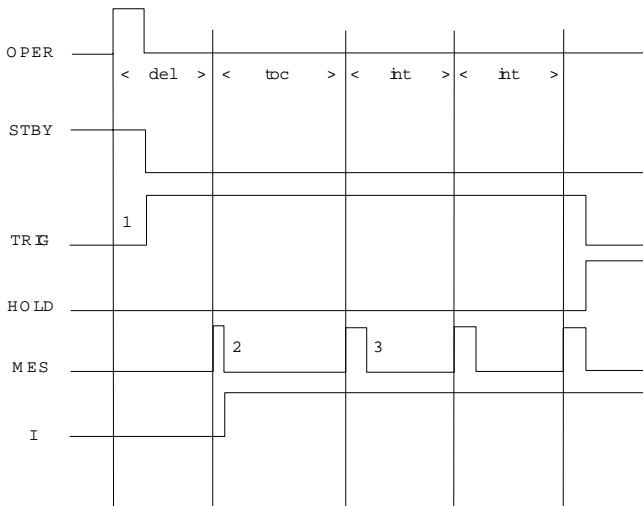

1: testing voltage wires (U) and first ambient temperature measurement if requested.

2: measuring offset voltage (stored).

3: first measurement.

5.7 OTHER FUNCTIONS

5.7.1 Relative measurement (ΔR)

The displayed value (L) is the algebraic difference between the real value (R) and an ohmic value stored in permanent memory (R0):
 $L = (R - R0)$.

R0 which depends on programmed function can be:
 - either fixed,
 - or equal to the last value measured by the unit.

Display of **NUL** symbol.

5.7.2 Relative measurement ($\Delta R / R$)

The principle is the same as for the ΔR function and the R0 value is obtained in the same way, except that the display reads:

$$L = (R - R0) / R0.$$

Display of **NUL** symbol.

5.7.3 Analog limits (clamping)

To avoid damaging an insulation layer (by oxidation for example) between two contacts by applying voltages higher than a few hundred millivolts, contact resistance standards advise clamping to 20 mV or to 50 mV relative to the voltage at the terminals of the component under test.

Activating or deactivating this limit is done by programming which is accompanied by the appearance or disappearance of the **LIM** symbol on the display.

5.7.4 Alarms

The unit has two alarm outputs whose limits (L1 and L2) have their value, hysteresis and direction programmable.

In case of malfunction, (see error message list in paragraph 5.3.1), an arbitrary measurement value (outside any possible measurement range) is attributed to each alarm level, according to the following tables:

OM 22		OM 24	
OVERLOAD	90 k Ω	OVERLOAD	900 k Ω
PROBE ?	50 k Ω	PROBE ?	500 k Ω
CLAMPING	40 k Ω	CLAMPING	400 k Ω
OVERRANGE	30 k Ω	OVERRANGE	300 k Ω
HIGH E.M.F.	- 1 k Ω	HIGH E.M.F.	- 1 k Ω
(U) OPEN	- 2 k Ω	(U) OPEN	- 2 k Ω
(I) OPEN	- 3 k Ω	(I) OPEN	- 3 k Ω
CURRENT < 1A	- 4 k Ω	CURRENT < 1A	- 4 k Ω
CONNECT. ERR	- 5 k Ω	CONNEX. ERR	- 5 k Ω

By choosing appropriate values for L1 and L2, alarms for certain or for all these malfunctions can be activated or deactivated.

5.7.5 Temperature compensation

Metals used in the windings of certain components (for example the copper wires in transformers or motors) have high temperature coefficients, of the order of 0.4 %/°C (copper or aluminum).

This means that the resistance measured is directly related to the temperature of the component.

Providing one knows the metal involved or its temperature coefficient, the "Temperature compensation" function displays the "Rt" value of the resistor reduced to a constant temperature of 20°C.

Activating this function displays the -//- symbol.

Do not forget to program determination mode of the ambient temperature (measured by means of a probe or fixed) as well as the metal selection or its temperature coefficient.

Selecting temperature measurement, implies connection of the probe as indicated at rear of the unit and checking for a time interval between two successive temperature measurements.

Running a measurement cycle:

Starts with measurement of the ambient temperature if programmed, then continues with resistance measurement compensated in temperature (Rt) and display.

When the measurement is correct (stable) changing for standby mode by pressing **STBY** key stores it into a special memory together with the time of change needed to current settling.

This memory can contain ten resistance values (Rt0 to Rt9) and ten time values (tc0 to tc9).

5.7.6 Heating measurement

The objective of this measurement is to determine the amount by which the temperature of a winding (transformer, motor, etc.) has risen due, in particular, to the thermal dissipation of the resistor under stress (self-heating).

The principle of this measurement is as follows:

Phase 1

With the winding cold (i.e. out of service for a sufficiently long time), the resistance "Rt" is measured and reduced to 20°C (see paragraph 5.7.5) together with the time of charge which are stored in the "Rt memory".

For that, program a first unit configuration with temperature compensation measurement with selection of the automatic "Rt" memory.

The unit can then be disconnected from the tested winding and switched off.

Phase 2

A second unit configuration should be programmed with heating measurement and "Rt" automatic memory. Once the winding has reached its working temperature, enter in this second configuration by pressing its number key.

The situation is now the following:

- the winding under test is still powered up,
- the unit is not connected to it,
- the display indicates **READY ?**.

From this moment, the user can stop the "Heating measurement" function by pressing the **STBY** key.

If not, simultaneously power down the component under test and press OPER.

This starts an internal timer. The display shows **MEASURE ?**; the terminals of the unit should now be connected to the winding and press **OPER** once more to start a measurement cycle.

Note:

This program automatically sets the measurement number Nb to 0 (permanent measurement) and the interval INT to 1 s (if INT was lower than this). However, before starting this type of measurement, check that the time delay DEL before the first measurement and the interval INT between two measurements are correctly programmed.

A value of a few seconds to a few tens of seconds for DEL, allowing thermal stability to have been reached before measuring offset and an interval INT of 1 s between measurements are usually adequate.

As the first correct measurement is displayed after a time t1 measured by the timer triggered by cutting power to the component under test (1st press on **OPER**) the unit continues measuring until time t2 defined as: $t2 = 5 * t1$. This t1 value is stored in burst memory if it is in use.

Taking into account the cold state resistance of the component (Rt) and the exponential decrease of its temperature, the unit computes the resistance of the component at time $t = 0$ at power cut-off and deduces the degree of heating present at that time.

The level of heating Δt is displayed in °C and an audible warning (beep) indicates the end of the procedure and the return to "Standby" position.

To carry out a similar heating measurement on another winding, reset the function as indicated above.

5.7.7 Resistance per unit length measurement (cables)

This function is used to measure the cable resistance, specially for multiwire cables measured on a drum length with all the wires short-circuited at ends.

Parameters to supply to the unit by program via the interfaces are as follows:

- the cable length (in meters),
- the number of wires,

and, after measurement, the unit indicates the average resistance per unit length per wire of this cable in Ω/km .

5.8 MEASUREMENT MEMORY

The instrument contains 1 000 memory registers, organized by burst into a maximum of 30 bursts numbered from 0 to 29.

The user can directly activate memory storage by programming whereupon the last character of the display shows the letter **m**.

Each time the unit is set to standby, either directly by pressing the STBY key, or indirectly by changing configuration a new burst is created.

At the 30th (burst n° 29), all burst numbers are decremented (the burst n° 0 disappears) and the last one created keeps the number 29.

In the same way, on the 1 000th measurement the older measurements disappear one by one.

A whole burst can be removed in this way once it no longer contains any measurements, which decrements the number of each following burst.

Note: changing range automatically, does not automatically create a new burst as each measurement is stored with its range.

Each burst is stored in memory with the following parameters:

- The number of measurements included.
- Time interval between measurements.
- Measuring current.
- Current waveform.
- In direct current mode:
 - . previous offset measurement (Vofs),
 - . Time Of Charge (TOC).
- In external current mode, the reference resistance value (Rref).
- In relative measurement mode, the reference resistance value (R0).
- In temperature compensation or heating measurement mode, the ambient temperature value and metal temperature coefficient.
- In heating measurement mode, the cold resistance value (Rt) and the time t1 between power down and the first measurement performed.

Note: in all modes, except temperature compensation, raw data is stored in memory, even when displayed values are different, as in the case of ΔR , $\Delta R / R$.

However, it is still possible to display processed values as all parameters are stored in the burst memory.

In "temperature compensation" mode, are stored the measurements reduced to 20°C (displayed measurements).

5.8.1 Immediate measurement clearing

When the memory is active, the last measurement, and only the last one, can be cleared immediately by pressing **CM**.

6. IEEE-488 and RS 232 interfaces

6.1 INTRODUCTION

The unit can be remote controlled by an IEEE-488 controller, a computer or a terminal, either via the asynchronous serial interface included as standard equipment on all instruments (RS-232), or by an optional IEEE-488 bus if installed.

For convenience, any unit or system capable of handling this remote control function will be referred to in this document as a controller.

The unit IEEE-488 interface has been implemented with the following functions:

AH1 SH1 T6 L4 SR1 RL1 PP0 DC1 DT0 C0 E2

The remote control mode and parameters can be changed by programming.

Most remote commands are the same for both modes, with exception of the following differences:

- The IEEE-488 mode will only work when the unit is powered by mains.
- In RS-232 mode:
 - . remote control is possible during battery-powered operation,
 - . The REM, LLO and LOC commands replace the corresponding messages of the IEEE-488 bus,
 - . there is no service request facility (SRQ),
 - . the IEEE-488 bus handshake is replaced by a protocol,
 - . the unit can directly drive a printer if this option is selected.

6.2 SYNTAX

The unit remote control commands meet the IEEE-488.2 standard.

6.2.1 Command messages

The controller talks to the unit by means of **command messages**. These messages can contain several elementary commands separated by <;> (hexadecimal code 3B or decimal code 59).

A message command must end with a **terminator**, as follows:

- either the character <LF> (hexadecimal code 0A or decimal code 10),
- or the message **EOI** on an IEEE-488 bus (line EOI active during the last character),
- or (<LF> + **EOI**).

In RS-232 mode, the terminator must always be an <LF>.

Characters in a message command can be either Upper or Lower Case.

Command message structure:

COMMAND1;COMMAND2;...;COMMANDn (EOI) or <LF> or (<LF> + EOI)

An elementary command which will be referred to as a **command**, is composed of a **header** followed by one or more **arguments** defining the command.

The header must be separated from arguments by at least one **space** < > (hexadecimal code 20 or decimal code 32) and arguments must be separated by <,> (hexadecimal code 2C or decimal code 44).

Extra spaces before or after header or argument are ignored.

Command headers conforming to IEEE-488.2 standard all start with a <,> character.

Command structure:

HEADER ARGUMENT1,ARGUMENT2,...,ARGUMENTn

The unit recognizes two types of argument: **decimals** and **mnemonics**.

Decimals:

Decimal arguments are used to specify a whole or fractional numerical value. They are composed of a mantissa and an optional exponent and may optionally be followed by a **suffix** if necessary.

The mantissa is a whole or fractional number (the whole and fractional parts are separated by <.>), with or without sign including a maximum of 255 characters (non-significant head zeros <0> excluded).

The exponent is a signed or unsigned whole number, up to four figures long, between - 3 200 and + 3 200.

Mantissa and exponent are separated by the character <e> or <E>. Spaces before or after the "e" or "E" are ignored.

The suffix associates a unit (or a multiple or a submultiple) to the numerical value.

The unit recognizes the following suffixes:

- UOHM ($\mu\Omega$), MOHM (m Ω), OHM, KOHM (k Ω).
- PCT (%).
- S (second).
- CEL ($^{\circ}\text{C}$).

Resistance values are expressed in Ohms by default.

Mnemonics:

Mnemonic arguments are used to specify optional parameters complementing a command. They are composed of a group of from one to twelve characters (alphanumeric or <_>) with a first alphabetic character.

The minimum and maximum number of arguments and the type of each one are specific to each command.

An optional argument can only be specified if its predecessor has been.

In the body of a command, arguments and optional suffixes are specified within brackets [].

6.2.2 Response messages

Certain commands imply a response from the unit. The headers of these commands end with <?> and are referred to as **queries**.

When a command message contains queries, the unit prepares a response message which normally should have been acknowledged by the controller before any command message is sent.

As a message command can contain several queries, the responses are placed in the response message according to the query order and are separated by <;>.

A response message ends with:
 - (<LF> + < EOI>), IEEE-488 bus,
 - (<CR> + < LF>), RS 232.

A response can contain several **response elements** separated by <,>.

The IEEE-488.2 standard defines eleven types of response elements; the unit supports the following ones:

- Mnemonic.
- Signed or unsigned decimal whole number (NR1).
- Decimal fractional number with **fixed decimal point** (NR2).
- Character string starting and finishing with <">.
- Eight-bit byte arbitrary block of indefinite length which starts with #0.
- Eight-bit byte arbitrary block of definite length which starts with #NX..X where:
 N: non-zero numerical character and
 X..X: N numerical characters representing in decimal notation the number of eight-bit bytes in the response element (not including #NX..X).
- Arbitrary block of 7 bit ASCII characters (except <LF>), always at the end of the message.

6.2.3 Detecting remote control errors

The IEEE-488.2 standard defines four types of errors according to their cause and report in the Event Status Register.

Command error:

Illegal command code (unknown header, illegal argument code, type or number of arguments different to those defined by the command). The command and all following message commands are not executed. The CDE bit of ESR is set to 1.

Execution error:

The command code is correct but cannot be executed as one or more arguments are out of limits specified in the command or are mutually inconsistent. All following message commands are executed. The EXE bit of ESR is set to 1.

Instrument error:

The command cannot be executed for reasons to do with the current state of the instrument. All following message commands are executed. The DDE bit of ESR is set to 1.

Query error: see exception procedures in paragraph 6.2.7.

When an error occurs, an error message is stored in a fault queue which can contain up to 16 entries. Above 16, the first ones are discarded.

6.2.4 Instrument registers, service request

The unit contains several 8 or 16 bit registers able to generate a service request through the report and enable actions.

One condition register:

ISR (Instrument Status Register).

Two event registers:

ESR (standard Event Status Register).
 ISCR (Instrument Status Change Register).

One status register:

STB (Status Byte) which stores the status word of the IEEE-488 interface each time a change occurs.

Three enable registers:

ESE (standard Event Status Enable).
 SRE (Service Request Enable).
 ISCE (Instrument Status Change Enable register).

Definition of register bits:

Bits:

7	6	5	4	3	2	1	0
---	---	---	---	---	---	---	---

16 bit registers only:

15	14	13	12	11	10	9	8
----	----	----	----	----	----	---	---

ISR, ISCR, ISCE:

PROB E	OVL	MEAS	ALAR M	HOLD	STBY	LOCK	REM
M_TA	LEAD	ACCU	OPEN I	OPEN U	HIEM F	OVR	CLAM P

ISCR register bits "REM", "LOCK" and "ALARM" are set to 1 when the corresponding ISR bit **changes state**; other bits are set to 1 only when their respective ISR bit **goes from 0 to 1**.

When an ISCR bit is set to 1, if the corresponding ISCE bit is at 1, the ISB bit of STB goes to 1.

REM:

Remote: the keypad is inactive.

LOCK:

Remote locked: only the controller can reset the unit to **Local**.

STBY:

Returns the instrument to standby as defined in para. 5.6.1.

HOLD:

At the end of a measurement cycle, the instrument goes to hold position as defined in paragraph 5.6.3.

ALARM:

Goes from 0 to 1 at the beginning of an alarm and from 1 to 0 at the end of an alarm when the function is active.

MEAS:

Goes from 0 to 1 when a new measurement is available.

OVL:

Overload: indicates the presence of an abnormal voltage on the instrument's inputs.

PROBE:

During ambient temperature measurements, indicates incorrect connections, an error value or the absence of a temperature sensor.

CLAMP:

Indicates an active voltage limit during a measurement when this function is active.

OVR:

Overrange: indicates an overrange of the active range when set to manual ranging, or an overrange of the highest range when set to autoranging.

HIEMF:
High E.M.F.: indicates an abnormally high value during offset voltage measurement (no current).

OPENU:
Indicates that the voltage circuit is open (terminals U).

OPENI:
Indicates an opening of or too high resistance across the current circuit (terminals I).

ACCU:
Indicates that the batteries which power the current source (OM 22) are discharged, hence it is not possible to work with the 10 A and 1 A current ranges.

LEAD:
Indicates an incorrect connection of the component under test, in particular the inversion of the voltage circuit compared to the current circuit.

M_TA:
Goes from 0 to 1 when a new ambient temperature measurement is available.

Note: *ISR and ISCR bits are set by both keypad and remote control commands.*

ESR, ESE:

PON		CDE	EXE	DDE	QYE		OPC
-----	--	-----	-----	-----	-----	--	-----

When an ESR bit is set to 1, if the corresponding ESE bit is at 1, the ESB bit of STB goes to 1.

PON:
Set to 1 at each power on cycle of the instrument or each time the IEEE-488 interface is initialized, and each time the interface mode changes (i.e.: each time the interface becomes active).

CDE:
Command error: unknown header or incorrect arguments. Subsequent message commands are not executed.

EXE:
Execution error: usually arguments out of limits. Subsequent message commands are executed.

DDE:
Instrument dependent error: usually arguments out of limits or inconsistent with the current state of the instrument. Subsequent message commands are executed.

QYE:
Query error: error acquiring a response message.

OPC:
Operation complete: set to 1 after the command .OPC as soon as all pending commands are complete.

STB, SRE, status word:

	MSS		ESB	MAV	EAV	ISB	
	RQS						

When one of the status word bits (other than RQS) goes to 1 and the corresponding SRE bit is set to 1, the RQS bit in the status word and the MSS bit in STB are set to 1 and the SRQ bus line becomes active.

When the controller receives the IEEE-488 interface status word by initiating a **Serial Poll**, the interface unasserts the SRQ line and the RQS bit goes to 0, whereas the MSS bit in STB only goes to 0 when the service request has disappeared.

ESB:
Reports the status of the Event Status Register.

MAV:
Message available: at least one eight-bit byte available in the output buffer.

EAV:
Error message available: at least one error message available in the fault queue.

ISB:
Reports the status of the Instrument Status Change Register.

6.2.5 Input buffer

IEEE-488 mode:

Each eight-bit byte received by the unit is stored in a memory zone called **input buffer**. This holds up to 128 eight-bit bytes and operates as a **first in first out** fashion (FIFO).

Each eight-bit byte of the input buffer is linked to an attribute which stores the state of the EOI line of the IEEE-488 interface and memorizes the GET message as a specific eight-bit byte.

The input buffer is transparent for the user, allowing the unit to receive data faster than it can decode them.

Once it is full, the unit inhibits the "handshake" by pulling down the NRFD (Not Ready For Data) line which is freed as soon as an eight-bit byte has been decoded, authorizing the controller to send a new eight-bit byte.

The input buffer is cleared during each power on cycle and each time a DCL (Device Clear) or SDC (Selected Device Clear) message are received on the IEEE-488 bus.

RS 232 mode:

The input buffer works in the same way, except for the following details:

- when in XON/XOFF protocol, if the input buffer contains more than 96 eight-bit bytes (75 %), the unit sends a Control/S (XOFF, hexadecimal 13 or decimal 19).

When the input buffer only contains 32 eight-bit bytes (25 %), it sends a Control/Q (XON, hexadecimal 11 or decimal 17).

When in CTS/DTR protocol, the CTS line of the serial interface is forced high or low as in XON/XOFF protocol (XON = + ; XOFF = -).

If the controller ignores the protocol and the input buffer capacity is exceeded, the unit stores no further characters and sends an error code.

- Control/D (hexadecimal 04 or decimal 4) and Control/T (hexadecimal 14 or decimal 20) have the same function as DCL and SDC messages on the IEEE-488 bus.

6.2.6 Output buffer

IEEE-488 mode:

Responses to queries are stored in a memory zone called an **output buffer** waiting till they are read by the controller. The output buffer holds up to 128 eight-bit bytes.

As soon as the unit is set to talk mode by the controller, the contents of the output buffer are sent over the bus, then once the whole of the response message has been received by the controller, the response terminator (<LF> + EOI) is sent over the bus.

RS 232 mode:

The output buffer works in the same way, except for the following details:

- In either protocol mode, the DTR line must be forced high before the serial interface can send characters.
- The interface only starts sending responses once the output buffer is full or a command message terminator has been decoded.
- In XON/XOFF protocol, the interface stops transmitting as soon as a Control/S (XOFF) has been received, and restarts transmitting as soon as a Control/Q (XON) has been received.

6.2.7 Exception procedures

If the controller does not follow IEEE-488.2 standard, exception procedures avoid total system hang ups.

INTERRUPTED:

The controller must read the response message before it attempts to send another command message. Otherwise, the QYE bit of ESR is set to 1, the output buffer is cleared and an INTERRUPTED error message is placed in the fault queue.

UNTERMINATED:

The controller must send a command message containing queries before it attempts to read a response message. Otherwise, the QYE bit of ESR is set to 1, the output buffer is cleared and an UNTERMINATED error message is placed in the fault queue.

DEADLOCKED:

A command message containing queries should not create a situation where the unit output buffer is full and there are still additional characters to be stored before the end of the message can be read. In this case the QYE bit of ESR is set to 1, the output buffer is cleared, a DEADLOCKED error message is placed in the fault queue and the rest of the command message is executed.

TRUNCATED RESPONSE:

When the response to a query should be placed as an arbitrary block of characters at the end of a message, it should not be followed by another query in the same command message. Otherwise, the QYE bit of ESR is set to 1, a TRUNCATED RESPONSE error message is placed in the fault queue and the responses to following queries are cleared from the response message.

6.2.8 Sequential and overlapped commands, commands ignored in local

Commands executed immediately as they are encountered are called sequential commands.

Commands that begin execution, but are completed some time later are called overlapped commands.

Most unit commands are sequential.

All commands which change unit configuration or the parameters stored in protected memory are ignored if the unit is in **local** mode. The DDE bit of ESR is set to 1 and a LOCAL error message is placed in the fault queue.

6.3 UNIT REMOTE COMMANDS

6.3.1 Commands defined by IEEE-488.2 standard

(and usable in RS 232)

.CLS (sequential command)

Clears the ESR and ISCR.
Argument: none.

.ESE (sequential command)

Programs the Event Status Enable register.
Argument: decimal number between 0 and 255.

.ESE? (sequential command)

Returns the value from the Event Status Enable register.
Argument: none.
Response: decimal whole number between 0 and 255.

.ESR? (sequential command)

Returns the value from the Event Status Register and clears it.
Argument: none.
Response: decimal whole number between 0 and 255.

.SRE (sequential command)

Program the Service Request Enable register.
Argument: decimal number between 0 and 255.

.SRE? (sequential command)

Returns the value from the Service Request Enable register.
Argument: none.
Response: decimal whole number between 0 and 255.

.STB? (sequential command)

Returns the value from the Status Byte register. Does not reset to 0 the MSS bit and asserts the SRQ line of IEEE-488 bus.
Argument: none.
Response: decimal whole number between 0 and 255.

.IDN? (sequential command)

Returns the unit identification.
Argument: none.
Response: arbitrary block of characters with four fields separated by <,>.

AOIP_MESURES, OM22, Sxxxxxxx, X.xx

Sxxxxxxx (Serial number)
X.xx (Software version)

.OPC (sequential command)

Sets the OPC bit of ESR register to 1 when all pending operations are complete.
Argument: none.

.OPC? (sequential command)

Returns a 1 when all pending operations are complete.
Argument: none.
Response: decimal whole number "1".

.WAI (sequential command)

Forces the unit to wait until all pending operations are complete.
Argument: none.

.TRG (overlapped command)

Acts like the **OPER** command (same as the GET bus message).
Argument: none.

.RST (sequential command)

Forces all pending commands to complete in the shortest possible time and resets the unit to its power on state (see para. 5.2).
Argument: none.

.TST? (sequential command)

Checks the integrity of the link between the analog and logic boards of the unit and controls the validity of the calibration coefficients.
Argument: none.
Response: decimal whole number according to the table:

0	No error.
1 to 10	Incorrect calibration coefficient. Defective sequence number.
11	Defective link.

.PSC (sequential command)

Checks the automatic reset of ESE and SRE registers to their power on state.
Argument: decimal number between - 32 767 and + 32 767.

If argument = 0, ESE and SRE keep the value they had before the previous instrument reset, which allows a service request as soon as the instrument is powered up.

If not, ESE and SRE are reset to 0 on power up and no service request is allowed before ESE and SRE have been reprogrammed.

Example: *PSC 0;*ESE 128;*SRE 32
will provoke a service request at each power up cycle.

.PSC? (sequential command)

Returns the status of the automatic reset flag of ESE and SRE.
Argument: none.
Response: decimal whole number 0 = no reset to 0.
1 = reset to 0.

6.3.2 Specific RS-232 mode commands

REM (sequential command)

Sets the instrument to remote control status; acts in the same way as the REN message of the IEEE-488 bus.
Argument: none.

LOC (sequential command)

Resets the instrument to local status; acts in the same way as the GTL message of the IEEE-488 bus.
Argument: none.

LLO (sequential command)

Inhibits a return to local mode using the LOC key; acts in the same way as the LLO message of IEEE-488 bus.
Argument: none.

6.3.3 Commands affecting the unit specific registers

ISCE (sequential command)

Programs the Instrument Status Change Enable register.
Argument: decimal number between 0 and 65 535.

ISCE? (sequential command)

Returns the value for the ISCE register.
Argument: none.
Response: decimal whole number between 0 and 65 535.

ISR? (sequential command)

Returns but does not clear the value from the Instrument Status Register.
Argument: none.
Response: decimal whole number between 0 and 65 535.

ISCR? (sequential command)

Returns and clears the value from the Instrument Status Change Register.
Argument: none.
Response: decimal whole number between 0 and 65 535.

6.3.4 Commands affecting working characteristics

CURRENT (sequential command ignored in local)

Programs the measurement current and, if it is external, the reference voltage and resistance

Arguments: **I**, [**V_REF**], [**R_REF**[UNIT]]

I, measurement current mnemonic (**EXT**, **A10** (OM 22), **A1**, **MA100**, **MA10**, **MA1**, **UA100**, **UA10** (OM 24)).

V_REF, optional mnemonic for external I reference voltage (**MV100**, **V1**).

R_REF, optional decimal number indicating the external I reference resistance value.

UNIT optional unit (**UOHM**, **MOHM**, **OHM**, **KOHM**, **OHM** by default).

CURRENT? (sequential command)

Returns the current value of the measurement current and, if it is external, the reference voltage and resistance.

Argument: none.

Response:

- I internal: (mnemonic).
- I external: (mnemonic, mnemonic, decimal number, mnemonic).

Examples: MA10

A1

EXT,MV100,10.013,MOHM

RANGE (sequential command ignored in local)

Programs the specified range if it is compatible with the active range, or the range change mode (manual or automatic).

Argument: **RAN**

RAN, range mnemonic (**UOHM200** (OM 22), **MOHM2**, **MOHM20**, **MOHM200**, **OHM2**, **OHM20**, **OHM200**, **KOHM2**, **KOHM20**, **KOHM200** (OM 24), **MANUAL**, **AUTO**).

RANGE? (sequential command)

Returns the active range **and** the range change mode (manual or automatic).

Argument: none.

Response: (mnemonic, mnemonic).

Examples: **OHM200,AUTO**
MOHM20,MANUAL

MODE (sequential command ignored in local)

Programs the current mode (pulse, alternate or direct).

Argument: **MODE**, [**MAX/AVR**]

MODE, current mode mnemonic (**PULSE**, **ALTERNATE**, **DIRECT**)
MAX/AVR, optional mnemonic indicating the choice between maximum measurement (**MAX**) or average measurement (**AVR**) in alternate mode.

MODE? (sequential command)

Returns the active current mode and, in alternate mode, indicates the choice between maximum measurement and average measurement.

Argument: none.

Response: (mnemonic), [mnemonic].

6.3.5 Commands affecting the measurement cycle

CYCLE (sequential command ignored in local)

Defines for the **OPER** command the number of measurements, the delay before the first measurement and the interval between two measurements (see paragraph 5.6.2).

The two last arguments (**DEL** and **INT**) are optional.

Arguments: **NB**, [**DEL**[**UNIT**]], [**INT**[**UNIT**]]

NB, whole number between 0 and 65 535.
DEL, decimal number between 0 and 32 400.
INT, decimal number between 0.5 and 32 400.
UNIT, unit <S> optional.

CYCLE? (sequential command)

Returns the measurement cycle parameters and burst memory state.

Argument: none.

Response: (whole number, decimal number, mnemonic (**MEM_OFF**, **MEM_ON**)).

Example: **20,00003.0,00000.5,MEM_ON**
(20 measurements, delay 3 s, interval 0.5 s, memory on)

TOC (sequential command ignored in local)

Defines for the **OPER** command, in direct current mode, the current time of charge before the first measurement.

Argument: **TIME**[**UNIT**]

TIME, decimal number between 0.5 and 32 400.
UNIT, unit <S> optional.

TOC? (sequential command)

Returns the current time of charge in direct current mode.

Argument: none.

Response: (decimal number).

Example: **00003.0**

OPER (overlapped command ignored in local)

Triggers a measurement cycle (refer to the manual command **OPER**, paragraph 5.6.2).

Argument: none.

MEAS? (sequential command)

Returns the value of the last measurement recorded (absolute value, no compensation) or, in case of malfunction, a predefined value (see paragraph 5.7.4).

Argument: none.

Response: (decimal number, mnemonic).

Examples: **125.09,MOHM**
203.47,OHM
30.000,KOHM (out of range, bit **OVR**
of **ISR**
to 1)

DSP? (sequential command)

Returns the value of the last measurement displayed (absolute or relative value, temperature compensated value) or, in case of malfunction, a predefined value (see paragraph 5.7.4).

Argument: none.

Response: (decimal number, mnemonic).

Examples: **-01.35,MOHM**
002.19,PCT

HEAT? (sequential command)

Returns the value of the last heating measurement.

Argument: none.

Response: (decimal number, mnemonic).

Example: **36.5,CEL**

TEMP? (sequential command)

Returns the value of the last ambient temperature measurement.

Argument: none.

Response: (decimal number, mnemonic).

Example: **25.3,CEL**

STBY (overlapped command ignored in local)

Returns the instrument to standby position (see paragraph 5.6.1).

Argument: none.

6.3.6 Commands affecting other functions

CLAMP (sequential command ignored in local)

Activates or deactivates the analog limits.

Argument: mnemonic.

OFF, deactivates the stored limit.
ON, activates the stored limit.
MV20, activates the 20 mV limit.
MV50, activates the 50 mV limit.

CLAMP? (sequential command)

Returns the stored limit and its state.

Argument: none.

Response: (mnemonic, mnemonic).

Example: MV20,OFF

ALARMS (sequential command ignored in local)

Activates or deactivates the alarm function.

Argument: **ON** or **OFF**.

ALARMS? (sequential command)

Returns the alarm function status.

Argument: none.

Response: (mnemonic), **ON** or **OFF**.

LIM_1 (sequential command ignored in local)

Programs the alarms limit 1.

Argument: **DIR**, [**VAL**[UNIT]], [**HYST**[UNIT]]

DIR, mnemonic indicating the direction of overrun of the limit which triggers the alarm:
- **HI** for value higher than limit,
- **LO** for value lower than limit.
VAL, decimal number indicating the value of the limit 1.
HYST, decimal number indicating the hysteresis value of the limit 1.
UNIT, optional unit (**UOHM**, **MOHM**, **OHM**, **KOHM**, **OHM** by default).

Example: LIM_1 HI,12.5KOHM,100

LIM_2 (sequential command ignored in local)

Programs the alarms limit 2.

Argument: **DIR**, [**VAL**[UNIT]], [**HYST**[UNIT]]

DIR, mnemonic indicating the direction of overrun of the limit which triggers the alarms:
- **HI** for value higher than limit,
- **LO** for value lower than limit.
VAL, decimal number indicating the value of the limit 2.
HYST, decimal number indicating the hysteresis value of the limit 2.
UNIT, optional unit (**UOHM**, **MOHM**, **OHM**, **KOHM**, **OHM** by default).

Example: LIM_2 LO,11.5KOHM,100OHM

LIM_1? (sequential command)

Returns the current programming of limit 1.

Argument: none.

Response: (mnemonic, decimal number, mnemonic, decimal number, mnemonic).
Value of limit and hysteresis have the same unit.

Example: HI,12.500,KOHM,00.100,KOHM

LIM_2? (sequential command)

Returns the current programming of limit 2.

Argument: none.

Response: (mnemonic, decimal number, mnemonic, decimal number, mnemonic).
Value of limit and hysteresis have the same unit.

Example: LO,11.500,KOHM,00.100,KOHM

MEAS_REL (sequential command ignored in local)

Activates or deactivates measurements of DR and DR/R.

Argument: mnemonic

OFF, deactivates the two functions.
DR, activates the function DR.
DR_R, activates the function DR/R.

REF_DR (sequential command ignored in local)

Programs the choice between measured or fixed reference value (R0) and, in the latter case, stores the new value.

Arguments: **MODE**, [**VAL**[UNIT]]

MODE, mnemonic indicating R0 measured (**MEAS**) or R0 fixed (**FIXED**).
VAL, decimal number indicating the value of R0.
UNIT, optional unit (**UOHM**, **MOHM**, **OHM**, **KOHM**, **OHM** by default).

Examples: REF_DR FIXED,100MOHM
REF_DR MEAS
REF_DR FIXED (stores the value of R0 in memory.)

MEAS_REL? (sequential command)

Returns the status of relative measurement functions, the entry mode of reference value R0 and its value.

Argument: none.

Response: (mnemonic, mnemonic, decimal number mnemonic).

Examples: DR_R,MEAS,101.05,MOHM
OFF,FIXED,15.728,OHM

MEAS_RT (sequential command ignored in local)

Activates or deactivates temperature compensated measurements (resistance at 20°C).

Argument: **ACT**, [**NO**]

ACT, mnemonic **ON** or **OFF**.
NO, optional whole number (if **ON**), between 0 and 9, indicating the "Rt" memory number where the measurement should be stored.

MEAS_DT (sequential command ignored in local)

Activates or deactivates heating measurement.

Argument: **ACT**, [NO]

ACT, mnemonic **ON** or **OFF**.
NO, optional whole number (if **ON**), between 0 and 9, indicating the "Rt" memory number containing the cold state measurement.

STORE_RT (sequential command ignored in local)

Enters a resistance value in the "Rt" memory.

Arguments: **NO**, **VAL**[UNIT]

NO, whole number between 0 and 9 indicating the "Rt" memory number.
VAL, decimal number indicating the resistance value to be stored.
UNIT, optional unit (**OHM** by default).

Examples: STORE_RT 7,125.34MOHM

TEMP (sequential command ignored in local)

Choice of entry mode of the ambient temperature between measured value and numerical entry and, in the latter case, the optional new temperature value.

Arguments: **MODE**, [VAL[UNIT]]

MODE, mnemonic indicating measured temperature (**MEAS**) or fixed temperature (**FIXED**).
VAL, optional decimal number indicating:
- in measured temperature, the time interval between two successive temperature measurements with its optional unit (**S**),
- in fixed temperature, the value of the ambient temperature with its optional unit (**CEL**).

Examples: TEMP MEAS,60 s
TEMP FIXED,28.5

METAL (sequential command ignored in local)

Choice of the metal type and of its temperature coefficient.

Arguments: **TYPE**, [VAL[UNIT]]

TYPE, mnemonic indicating metal type:
- **CU**, copper, Tc = 0.3931 %/°C,
- **AL**, aluminum, Tc = 0.4030 %/°C.
- **OTHER**, another metal or temperature coefficients different from those set for copper and aluminum.
VAL, decimal number indicating the temperature coefficient of metals other than those of copper or aluminum proposed.
UNIT, optional unit (PCT = %/°C).

Examples: METAL OTHER,0.00391
METAL OTHER,0.391PCT
METAL CU
METAL OTHER
(reminder of coefficient
0,391%/°C previously
stored).

LIGHT (sequential command ignored in local)

Argument: mnemonic **OFF** or **ON**.
Activates or deactivates the display lighting.

MEAS_CT? (sequential command)

Returns the status of functions linked to the temperature of component under test, the temperature entry mode, the metal type and its temperature coefficient.

Argument: none.
Response: (mnemonic, mnemonic, decimal number, mnemonic, decimal number, mnemonic).

Examples:
OFF,MEAS,00060.0,S,CU,0.3931,PCT
RT,FIXED,028.5,CEL,OTHER,0.3910,PCT

MEM_RT? (sequential command)

Returns the contents of the memory with 10 resistance values reduced to 20°C (Rt0 to Rt9).

Argument: none.
Response: eight-bit byte block of definite length.

Example:
#40131
10.014 MOHM (memory n° 0)
198.05 MOHM (memory n° 1)
04.832 OHM (memory n° 2)
.....
08.547 KOHM (memory n° 9)

MEMRT? (sequential command)

Returns the contents of the memory with 10 resistance values reduced to 20°C (Rt0 to Rt9) and the corresponding time of charge.

Argument: none.
Response: eight-bit byte block of definite length.

Example:
#40232
10.014 MOHM,00000.5 S (memory n° 0)
198.05 MOHM,00002.5 S (memory n° 1)
04.832 OHM,00004.0 S (memory n° 2)
.....
08.547 KOHM,00008.5 S (memory n° 9)

OUT_ANA (sequential command ignored in local)

Programs the analog output setup parameters.

Argument: **MIN** [UNIT],[**MAX**[UNIT]]

MIN, decimal number corresponding to the output 0 V.
MAX, decimal number corresponding to the output 2.50 V.
UNIT, optional unit (**UOHM**, **MOHM**, **OHM**, **KOHM**, **OHM** by default).

Examples: OUT_ANA 0,15MOHM
OUT_ANA 5MOHM (modification of MIN
exclusively).

OUT_ANA? (sequential command)

Returns the analog output setup parameters.

Argument: none.
Response: (decimal number, mnemonic, decimal number, mnemonic).

Example: 05.000,MOHM,15.000,MOHM

RPUL (sequential command ignored in local).

Activates or deactivates the cable resistance measurements and programs the parameters.

Arguments: **ACT** [,**LENGTH** [,**WIRES**]]

ACT, mnemonic ON or OFF.
LENGTH, decimal number indicating the cable length in **meters** ($100 \leq \text{LENGTH} \leq 9\,999$).
WIRES, decimal number indicating the number of wires ($1 \leq \text{WIRES} \leq 100$).

RPUL? (sequential command)

Returns state and parameters of the cable resistance measurement.

Argument: none.

Response: mnemonic, decimal number, decimal number.

Example: ON,1200.0,10 (in use, 1 200 m, 10 wires).

6.3.7 Configuration commands

NAT (sequential command ignored in local)

Programs the language (French, English, German, Spanish, Italian).

Argument: nationality mnemonic (F, GB, D, E, I).

RS232 (sequential command ignored in local)

Programs the RS-232 interface parameters.

Arguments: **PROTOCOL** [,**BAUDS** [,**PARITY** [,**NB_BITS** [,**NB_STOPS**]]]]

PROTOCOL, mnemonic of the protocol used:
- **NOP**, no protocol.
- **XON**, XON/XOFF protocol.
- **CTS**, CTS/DTR protocol.
- **PRT**, printer mode.

BAUDS, mnemonic of the transmission rate:
19200, **9600**, **4800**, **2400**, **1200**, **600**, **300**.

PARITY, mnemonic of the parity check:
- **N**, no parity.
- **X** ignore parity.
- **O**, odd parity.
- **E**, even parity.

NB_BITS, decimal number indicating the number of bits transmitted ($7 \leq \text{NB_BITS} \leq 8$)

NB_STOPS, decimal number indicating the number of stop bits ($1 \leq \text{NB_STOPS} \leq 2$).

IEEE (sequential command ignored in local)

Programs the IEEE address.

Argument: **ADDRESS** ($0 \leq \text{Add} \leq 30$).

PRINT (sequential command ignored in local)

Activates or deactivates sending of measurements to the printer (RS 232 with "printer" protocol).

Arguments: **ACT** [,**NB_COL**]

ACT, mnemonic ON or OFF.

NB_COL, decimal number indicating the number of columns ($0 \leq \text{NB_COL} \leq 10$).

NB_COL = 0 for computer output (PC), page of infinite length.

SAVE_CONF (sequential command ignored in local)

Saves the actual configuration of the unit in the key whose number is indicated.

Argument: **NO**, decimal number ($1 \leq \text{NO} \leq 6$).

LOAD_CONF (sequential command ignored in local)

Loads and uses the configuration memorized in the key whose number is indicated.

Argument: **NO**, decimal number ($1 \leq \text{NO} \leq 6$).

CONF_NO? (sequential command)

Transmits the **number** of the configuration in use.

Argument: none.

Response: decimal number between 1 and 6.

CONF? (sequential command)

Transmits the configuration of the number indicated or, by default, the configuration in use.

Argument: [**NO**], decimal number ($1 \leq \text{NO} \leq 6$).

Response:

```
#0
CONF <NO>
CYCLE <same response as CYCLE?>
CURRENT <same response as CURRENT?>
MODE <same response as MODE?>
RANGE <same response as RANGE?>
MEAS_REL <same response as MEAS_REL?>
MEAS_CT <same response as MEAS_CT?>
RPUL <same response as RPUL?>
CLAMP <same response as CLAMP?>
ALARMS <same response as ALARMS?>
LIM_1 <same response as LIM_1?>
LIM_2 <same response as LIM_2?>
OUT_ANA <same response as OUT_ANA?>
```

Example:

```
#0
CONF <NO>
CYCLE 3,00000.0,00000.5,MEM_OFF
CURRENT MA100
MODE DIRECT
RANGE OHM20,MANUAL
MEAS_REL OFF,MEAS,100.00,MOHM
MEAS_CT RT,MEAS,00060.0,S,CU,0.3931,PCT
RPUL OFF,100.0,1
CLAMP MV20,OFF
ALARMS OFF
LIM_1 HI,20.000,KOHM,00.001,KOHM
LIM_2 LO,-.1000,KOHM,0.0010,KOHM
OUT_ANA 000.00,UOHM,250.00,OHM
```

6.3.8 Commands affecting the burst memory

MEMORY (sequential command ignored in local)

Activates or deactivates the measurement memory.

Argument: **OFF** or **ON**.

MEMORY? (sequential command)

Returns the summary contents of the measurement memory, i.e. the number of bursts and, for each burst (numbered from B_00 to B_29 max.), the number of measurements and the measurement current (in external I, remainder of the reference resistance value).

Argument: none.

Response: eight-bit byte of indefinite length.

Example 1 (memory empty):

```
#0
00 BURST
```

Example 2:

```
#0
04 BURST
B_00,0021 MEAS,MA100
B_01,0063 MEAS,A1
B_02,0178 MEAS,MA10
B_03,0045 MEAS,EXT,10.014,MOHM
```

BURST? (sequential command)

Returns the number of bursts recorded.

Argument: none.

Response: (decimal number).

Example: 15

OUT_BURST? (sequential command)

Returns, without argument, the contents of the last burst recorded, or the contents of the burst with the number contained in the argument. If this number is higher than number of bursts recorded, returns the number of bursts.

Arguments (optional): [NO], [TYPE]

NO, whole number between 0 and 29.

TYPE, mnemonic indicating the measurement value returned:

- **DR**, relative measurement (R - R0),
- **DR_R**, relative measurement (R - R0 / R0),
- by default, absolute value or value reduced to 20°C.

Response: eight-bit byte block of indefinite length.

Line 1:
#0

```
Line 2:
00 BURST (memory empty)
xx BURST (argument too large)
B_xx (output burst n° xx)
```

```
Line 3:
xxxx MEAS,ABS,(VAL) (UNIT)
(absolute measurement, R0 value = 0)
or
xxxx MEAS,REL,(VAL) (UNIT)
(relative measurement, R0 value)
or
xxxx MEAS,RT,(VAL) (UNIT)
(measurement reduced to 20°C, R0 value)
or
xxxx MEAS,DT,(VAL) (UNIT)
(heating measurement, Rt value)
```

```
Line 4:
CURRENT [I],(VAL) (UNIT)
(current mnemonic, internal Rref)
or
CURRENT EXT,(VAL) (UNIT)
(external Rref)
```

```
Line 5:
(current mode mnemonic) MODE
```

```
Line 6:
INT : xxxxx.x S (Interval between measurements)
```

```
Lines 7, 8, 9:
MAX : (VAL) (UNIT) (maximum value)
MIN : (VAL) (UNIT) (minimum value)
AVR : (VAL) (UNIT) (average value)
```

```
Line 10:
TA : (VAL) CEL, TC : (VAL) PCT
(if Rt or Dt measurement)
TA : 020.0 CEL, TC : 0.0000 PCT
(if measurement independent of T)
```

```
Line 11:
DT : (VAL) CEL (if Dt measurement)
DT : 000.0 CEL (other measurements)
```

Following lines, measurement values with option TYPE:

(VAL) (UNIT)	(measurement 0 of the burst)
(VAL) (UNIT)	(measurement 1 of the burst)
.....	
(VAL) (UNIT)	(last measurement of the burst)

Example 1: OUT_BURST? 45
(output of contents of burst n° 45 when the memory only contains 10 bursts).
#0
10 BURST

```
Example 2: OUT_BURST? 5
(output of contents of burst n° 5 containing 4 absolute measurements).
#0
B_05
0004 MEAS,ABS,000.00 UOHM
CURRENT MA100,1.0000 OHM
PULSE MODE
INT : 00001.5 S
MAX : 115.24 MOHM
MIN : 115.20 MOHM
AVR : 115.22 MOHM
TA : 020.0 CEL, TC : 0.0000 PCT
DT : 000.0 CEL
115.20 MOHM
115.23 MOHM
115.21 MOHM
115.24 MOHM
```

```
Example 3: OUT_BURST? 7,RT
(output of contents of burst n° 7 containing 3 measurements with temperature compensation).
#0
B_07
0003 MEAS,RT,000.00 UOHM
CURRENT EXT,10.115 MOHM
DIRECT MODE
INT : 00001.0 S
MAX : 17.543 MOHM
MIN : 17.539 MOHM
AVR : 17.540 MOHM
TA : 025.4 CEL, TC : 0.3931 PCT
DT : 000.0 CEL
17.543 MOHM
17.539 MOHM
17.539 MOHM
```

OUTBURST? (sequential command)

Returns, without argument, the contents of the last burst recorded, or the contents of the burst with the number contained in the argument. If this number is higher than number of bursts recorded, returns the number of bursts.

Argument (optional): **[NO]** , whole number between 0 and 29.
Response: eight-bit byte of indefinite length.

Line 1:
#0

Line 2:
00 BURST (memory empty)
xx BURST (argument too large)
B_xx (output burst n° xx)

Line 3:
xxxx MEAS,ABS (absolute measurement)
or
xxxx MEAS,RT (measurement reduced to 20°C)
or
xxxx MEAS,DT (heating measurement)

Line 4:
(current mode mnemonic) MODE

Line 5:
CURRENT [I],REF (VAL) (UNIT)
(current mnemonic, reference resistance)

Line 6:
R0 (VAL) (UNIT),RT (VAL) (UNIT)
(R0 value, relative measurements),
(RT value, heating measurements)

Line 7:
INT xxxxx.x S,TOC xxxxx.x S,T1 xxxxx.x S
(Interval between measurements, time of charge, first measurement time in heating measurement).

Line 8:
TA (VAL) CEL,TC (VAL) PCT,DT (VAL) CEL
(ambient temperature, temperature coefficient, heating).

Line 9:
VOFS (VAL) MV
(stray e.m.f measurement in direct current mode).

Line 10:
^ (record separator, decimal code 30)

Lines following, measurement values:
(VAL) (UNIT) (measurement 0 of the burst)
(VAL) (UNIT) (measurement 1 of the burst)
.....
(VAL) (UNIT) (last measurement of the burst)

Last lines:
^ (record separator, decimal code 30)
MAX (VAL UNIT),MIN (VAL UNIT),AVR (VAL UNIT)
(maximum, minimum and average value)
→ (RS232 only: file end, decimal code 26)

Example 1: OUTBURST? 45
(output of contents of burst n° 45 when the memory only contains 10 bursts).

#0
10 BURST
→

Example 2: OUTBURST? 3
(output of contents of burst n° 3 containing 24 heating measurements).

#0
B 03
24 MEAS,DT
DIRECT MODE
CURRENT A1,REF 100.00 MOHM
R0 000.00 UOHM,RT 2.0461 OHM
INT 00001.0 S,TOC 00002.5 S,T1 00006.0 S
TA 023.7 CEL,TC 0.3931 PCT,DT 21.4 CEL
VOFS -000.2 MV
^
2.0704 OHM
2.0698 OHM
2.0692 OHM
.....
2.0572 OHM
^
MAX 2.0704 OHM,MIN 2.0572 OHM,AVR 2.0651 OHM
→

OUT_MEMORY? (sequential command)

Returns the contents (absolute measurements) of all the bursts in memory.

Argument: none.

Response: eight-bit block of indefinite length.

- if the memory is empty:
#0
00 BURST

- if the memory contains "n" bursts:
#0
(same as OUT_BURST? 0)
(same as OUT_BURST? 1)
.....
(same as OUT_BURST? n-1)

OUTMEMORY? (sequential command)

Returns the contents (absolute measurements) of all the bursts in memory.

Argument: none.

Response: eight-bit block of indefinite length.

- if the memory is empty:
#0
00 BURST

- if the memory contains "n" bursts:
#0
(same as OUTBURST? 0)
(same as OUTBURST? 1)
.....
(same as OUTBURST? n-1)
→ (RS232 only: file end, decimal code 26)

DEL_BURST (sequential command ignored in local)

Deletes the burst whose number is indicated in the argument.

Argument: whole number between 0 and 29.

DEL_MEMORY (sequential command ignored in local)

WARNING: this command deletes all the measurement memory.

Argument: none.

6.3.9 Error commands

The 16 last errors detected during decoding or execution of commands are stored in a fault queue.

The EAV bit of STB is set to 1 as long as there is at least an error message in the queue.

CL_ERR (sequential command)

Clears all error messages and resets EAV bit to 0.

Argument: none.

ERR_NO? (sequential command)

Returns the most recent error number and clears the corresponding message from the queue. If there are no more error messages waiting, the EAV bit is reset to 0.

Argument: none.

Response: decimal whole number, 0 is no error.

ERR? (sequential command)

Returns the message corresponding to the most recent error or the error number contained in the argument.

Argument: optional decimal number between 0 and 29.

Response: Character string between "<".

- With no argument, the command ERR? acts just like ERR_NO? towards the fault queue.
- With argument, the fault queue is not modified.

Table of errors	
Error n°	Message
0	"NONE ERROR"
1	"UNTERMINATED"
2	"INTERRUPTED"
3	"DEADLOCKED"
4	"TRUNCATED RESPONSE"
5	"UNKNOWN HEADER"
6	"GET ENCOUNTERED"
7	"WRONG ARG. TYPE"
8	"WRONG ARG. NO."
9	"OVERLIMIT ARG."
10	"UNKNOWN MNEMONIC"
11	"WRONG SUFFIX"
12	"ARG. TOO LONG"
13	"WRONG ARG."
14	"LOCAL"
15	"DEVICE ERROR"
16	"TRIG. IN PROGRESS"
17	"WAIT DISCHARGE"
18	"OVERLOAD"
19	"OVERRANGE"
20	"CURRENT TOO HIGH"
21	"OPEN U"
22	"OPEN I"
23	"CLAMPING"
24	"HIGH EMF"
25	"CONNECTION ERROR"
26	"CALIBRATION ERROR"
27	"PROBE ERROR"
28	"INPUT BUFFER FULL"
29	"WRONG ERROR NO."

7. Maintenance

In view of the precautions required and the risks involved, all maintenance procedures must be undertaken by qualified personnel, adequately trained and documented. AOIP offers a full maintenance and calibration service in its factory and assumes no risk for repair or calibration activities undertaken by other personnel. All maintenance operations must be performed on a totally disconnected unit, except for those relating to the battery charger.

7.1 OPENING THE UPPER AND LOWER COVERS

- Disconnect the instrument from the power supply and from all electrical cabling wires to both front and rear panel terminal blocks.
- Using a screwdriver, unscrew the 4 cover screws on the side to be opened, each cover is fixed by 2 short screws at the rear and 2 long screws at the sides.
- Lift the cover and pull towards the rear of the instrument.

The upper cover provides access to:
 . the logic board and, if required, the 12 V battery and the charger board,
 . optionally the IEEE-488 board, according to model.

The lower cover provides access to:
 . the analog board.

7.2 CLOSING THE CASE

- Align the two tabs on the cover into the slots in the case, pushing the cover into position.
- Insert the 4 screws into the cover to complete replacement onto case.

WARNING: The 2 short screws go in the holes at the rear of the instrument and the 2 long screws go in the sides.

7.3 REPLACING FUSES

7.3.1 Power fuse

The instrument's power supply is protected by a time-lag 5 x 20 fuse rated 160 mA/250 V, according to standard NF C 60-430 (sheet III). In the "~" indicator does not light up when the instrument is connected to power supply, replace the fuse as follows:

- Switch off the instrument, disconnect the power cord as well as all wires connected to the front or back of the instrument.
- Open the upper cover as described in paragraph 7.1. The fuse is located on the logic board as shown in the following diagram:

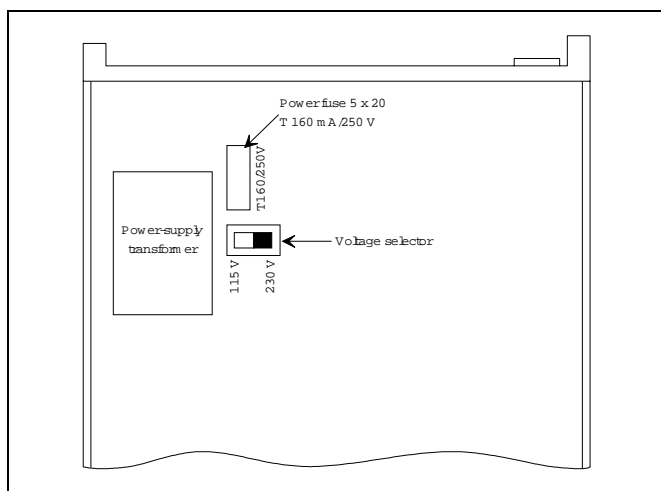

- Remove the fuse cover.
- Insert the blade of a small screwdriver between the fuse and its support, exerting light pressure to push it up and out of its clips.
- Check that the fuse is blown, and identify the malfunction which caused it to blow.
- Replace the fuse with an identical part: AOIP part number ER 48124-161.
- Put back the fuse cover.
- Close up the instrument as described in paragraph 7.2.

7.3.2 Current circuit fuse

The analog board current circuit is protected by:

- a 6.3 x 32 instantaneous fuse rated 16 A/250 V, specially made to ensure low voltage drop (standard NF C 93-435, model HA 39) for the OM 22 (AOIP part number: AN 8009),
- a 6.3 x 32 fast-acting fuse rated 2 A/380 V for the OM 24 (AOIP part number: AN 5826).

If, as a result of a manipulation error, the units outputs no current to the " I " terminals, check if the fuse is blown, that no other component nearby is damaged or destroyed, and only then **replace it with an identical component.**

To replace it:

- **Switch off the instrument, disconnect the power cord as well as all wires connected to the front or back of the instrument.**
- Open the lower cover as described in para. 7.1. The fuse is located on the analog board, near the rear terminal block.
- Replace the fuse and close the instrument as described in paragraph 7.2.

7.4 POWER SUPPLY 230 V OR 115 V

To change power supply:

- **Switch off the instrument, disconnect the power cord as well as all wires connected to the front or back of the instrument.**
- Open the lower cover as described in paragraph 7.1.
- Move the "voltage selector" to the desired position as indicated on the diagram in paragraph 7.3.1
- Add a label indicating the new voltage under the plug fixed to the rear panel.

7.5 SERVICING THE BATTERY PACK (OM 22)

Models OM 22-2 and OM 22-4 are equipped with a 12 V battery pack. This is contained in a molded tight pack allowing operation in any position. This battery normally needs no servicing other than making sure it is adequately charged.

7.5.1 Normal usage

As soon as the instrument is connected to power supply, the red indicator (~), to the right of the keypad lights up indicating power presence; the internal charger recharges the battery according to its discharge level, independently whether the instrument is working or not.

When working independently, the user is warned the battery should be recharged by the appearance of a symbol **BAT** on the display.

At that point there remains approx. 20 % of a full charge, i.e. after a certain period varying from 30 to 90 minutes, according to usage, the instrument will switch off automatically and it will no longer be possible to switch it back on. **The battery must be immediately recharged if irreversible damage is to be avoided.**

To do this, plug the instrument back into power supply, the red indicator lights up. The battery recharges itself. A full charge takes from 12 to 14 hours. Beyond this time, the charger limits the current feed and the instrument can stay plugged in for an unlimited time.

7.5.2 Storage

Unit battery life is improved if the following advice is followed:

- Never store an instrument whose battery is completely discharged.
- Recharge it after each period of usage, do not just wait for the **BAT** symbol to appear before recharging.
- After a complete discharge and an automatic cut-out, anything more than a few days in this state can reduce the nominal charge capacity of the battery and the unit will lose some of its autonomy.

If long-term storage is envisaged, remember that a lead battery always has a certain current leakage, depending on ambient temperature. Periodic top-up recharging is advisable in order to compensate this natural tendency to self-discharge:

- with a totally charged battery, storage at temperatures below 25°C requires top-up recharging every 12 months,
- storage at temperatures from 30°C to 40°C requires top-up recharging approximately every 6 months.

7.5.3 Replacing the battery pack

In case of battery abnormal operation or if the life is highly reduced regarding that indicated in the technical specifications, the user may replace the battery with an identical part (tight lead battery pack, 12 V, 1.8 to 2.0 Ah), AOIP part number: ER 41206-003.

7.6 EXTERNAL POWER SUPPLY (OM 22)

- To install the current source external supply:
- connect the 3 V external power supply and **follow the polarity.**
 - using a screwdriver, set the "source" switch to external position (slot via the "3 V" input terminals).

7.7 PERFORMANCE VERIFICATION

The instrument's performance to specification is checked exhaustively at the factory before shipment.

However the user may need to verify exact performance characteristics as part of the company's metrology and quality policy.

This check should take into account normal metrological procedure and usage and in particular the following advice should be followed:

- All operations should be performed in the following reference conditions: temperature: 23°C ± 1°C, relative humidity: 45 % to 75 %.
- The calibration standards used for performance verification or calibration should be chosen to ensure that the accuracy across the verification or calibration terminals is known and, for the unit, is equal or better than ± 0.01 %, taking into account the influence factors present.

After this verification, if one or more performance characteristics of the unit are outside specified tolerances, the instrument can be recalibrated by the user.

The unit calibration is explained in a maintenance document, AOIP part number: NT 45942-190B.

8. Warranty

The unit is covered by a one year factory warranty, including parts and labor, against any defect encountered during normal usage, excluding any faults caused by abnormal usage or repairs by personnel other than those qualified by AOIP.

In case of malfunction, send the instrument back to the address indicated below or to a repair laboratory approved by AOIP to ensure the repair quality and the calibration accuracy as specified in para. 4.2.

AOIP INSTRUMENTATION
Service Après-Vente
Zone Industrielle de Saint-Guénault
Rue Maryse Bastié
B.P 182 - 91006 EVRY CEDEX - FRANCE

Tel: +33 1 69 36 50 50