

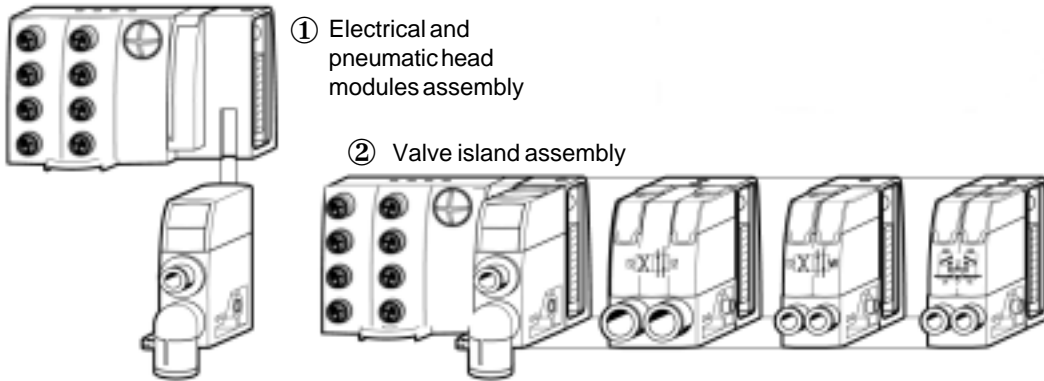

- Assembly

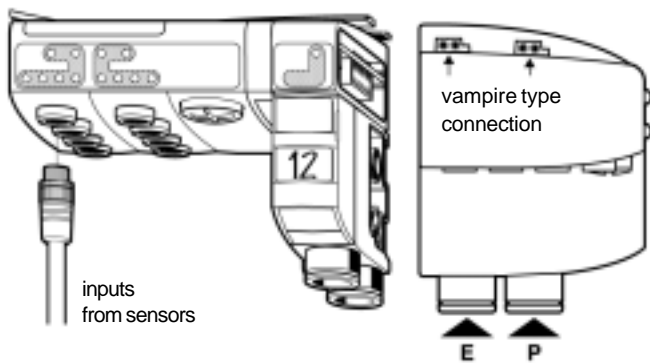

AS-i bus connection



- Maintenance

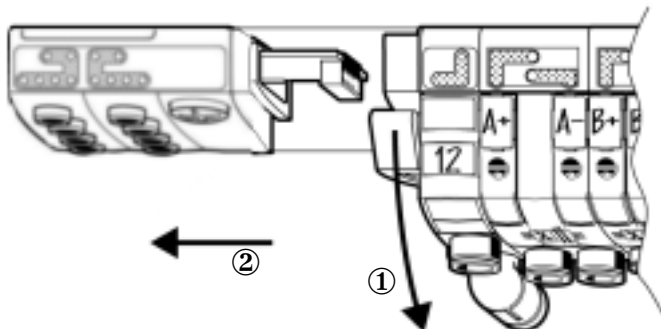

Specifications

EMC / CE mark.	According to EN 61 000-6-2 and to EN 61 000-6-4
AS-i line	According to EN 50295
Solenoid pilot voltage	24 V DC
Module consumption	max. 70 mA (2 slaves)
Max. supply for all inputs	240 mA (including internal input consumption)
Internal input consumption	9 mA for each active input
Inputs	According to IEC 1131-2 class 2
Ext. Output power	2,5 W

Bus addressing, first and second node

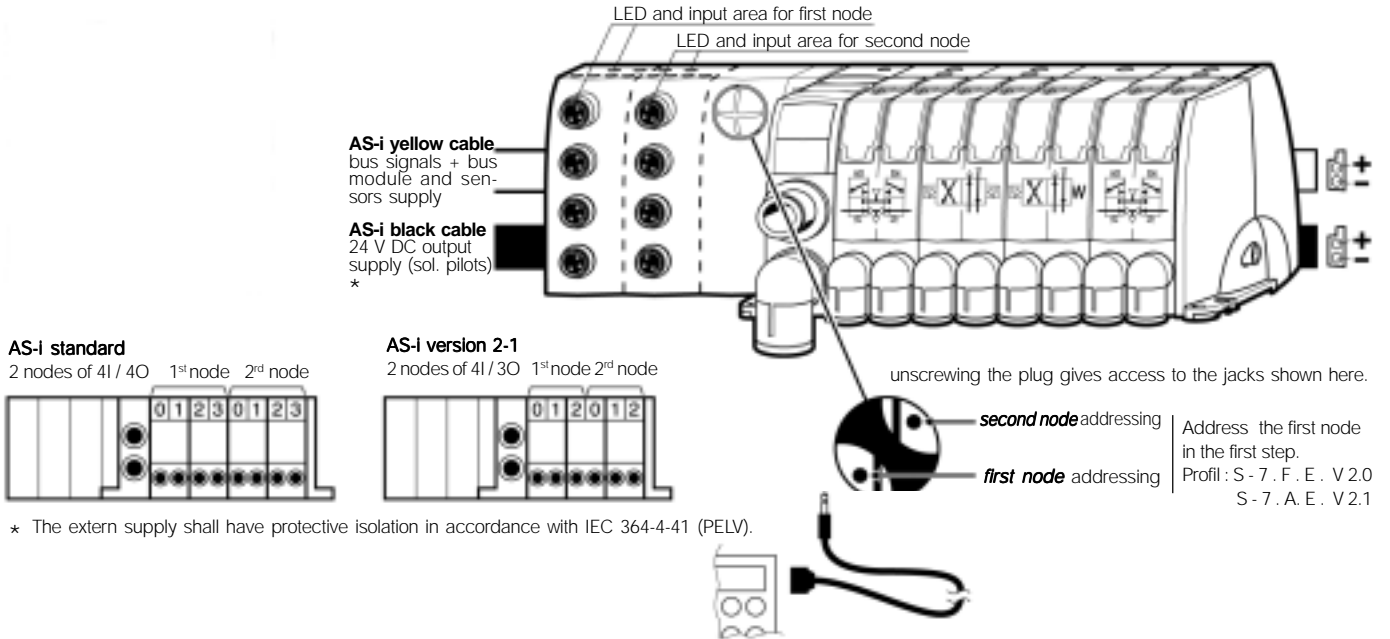

Bus diagnostic

first node green red
second node green red

white area for address marking
input LED D (0 1 2 3) (see examples below)

«power» LED state	off	green	red
Power supply	sol. pilot supply	normal operation	solenoid overload

first node LEDs state		second node LEDs state		System condition
green LED	red LED	green LED	red LED	
●	○	●	○	Normal operation
○	○	○	○	No module + sensor supply
○	⊗	○	⊗	Input overload
○	●	○	⊗	No AS-i communication
⊗	●	○	⊗	Address first node = 0
●	○	⊗	●	Address second node = 0

● ON ○ OFF ⊗ BLINK

Input wiring

Physical input (I, II, III, IV) = D (0 1 2 3) first node, physical input (V, VI, VII, VIII) = D (0 1 2 3) second node
 Examples : physical input III = logical input 6.2, physical input V = logical input 7.0

M8 female connectors

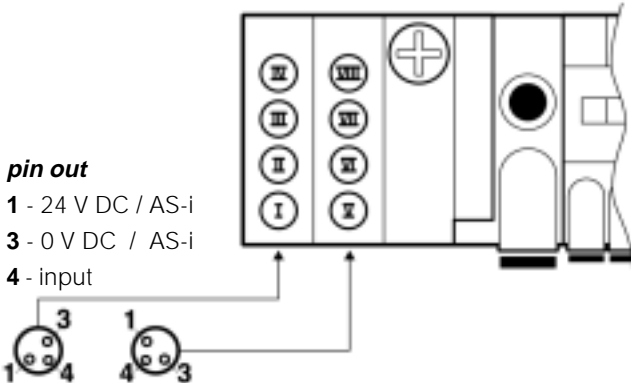

M12 female connectors

