



A Halma company



OPERATING MANUAL

FOR LIQUID FLOW METERS

Models L · LB · LS · LBS

Thank you for purchasing your liquid mass flow meter.

If you have any questions, or if something is not working as expected, please contact us. We are eager to help you in any way possible.

Contact Information

World Headquarters, Tucson, Arizona, USA

info@alicat.com
alicat.com
7641 N Business Park Dr.,
Tucson, AZ 85743 USA
+1 888-290-6060

Europe

europe@alicat.com
Geograaf 24
6921 EW Duiven
The Netherlands
+31 (0) 26 203.1651

China & SE Asia

info-cn@alicat.com
alicat.com.cn
2nd Floor, Block 63, No. 421,
Hong Cao Rd,
Shanghai 200233
PRC
+86-21-60407398 ext. 801

India

india@alicat.com
Halma India Pvt. Ltd.
Plot No . A-147, Road No. 24,
Next to Spraytech Circle
opp. Metropolitan Company,
Wagle Industrial Estate
Thane-West
Mahārāshtra 400 604
+91 022-41248010

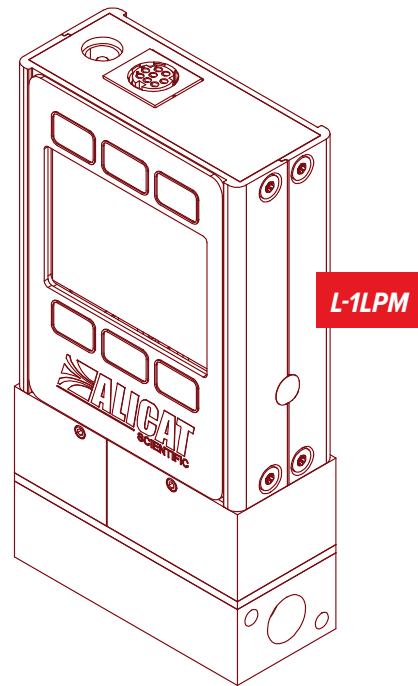

Recalibrate your mass flow meter every year.

Annual calibration is necessary to ensure the accuracy of readings, and extend the Limited Lifetime Warranty. Fill out the Service Request Form at alicat.com/service, or contact us directly when it is time for recalibration.

For devices ordered with CSA, ATEX, ISO 17025, or other certifications, please visit alicat.com/certifications. For information about our limited lifetime warranty, visit alicat.com/warranty.

Serial #: _____

Next Calibration: _____



This device comes with a NIST-traceable calibration certificate.



This device conforms to the European Union's Restriction of Use of Hazardous Substances in Electrical and Electronic Equipment (RoHS) Directive 2011/65/EU.



This device complies with the requirements of the Low Voltage Directive 2014/35/EU and the EMC Directive 2014/30/EU and carries the CE Marking accordingly.



This device complies with the requirements of the European Union's Waste Electrical & Electronic Equipment (WEEE) Directive 2002/96/EC

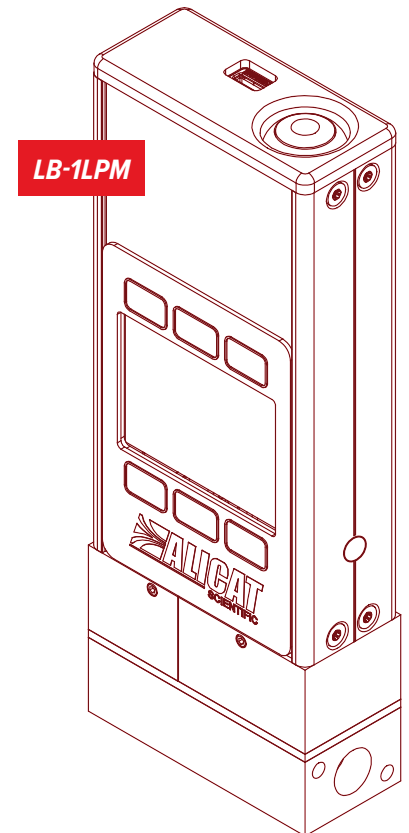

Introduction

Your new flow meter has a variety of innovative features:

- **1000 readings per second** guarantees high resolution data, [page 9](#).
- **Monitor live pressure and temperature** during flow measurement, [page 10](#).
- **Backlit display with adjustable contrast** is easy to read even in direct sunlight. In dimly lit areas, press the logo to turn on the backlight, [page 13](#).
- **Connection to a computer** for control and data logging to capture all pressure data for logging and analysis, [page 14](#).

This manual covers the following instruments:

- L-Series: liquid flow meters
- LB-Series: portable liquid flow meters
- LS-Series: anti-corrosive liquid flow meters
- LBS-Series: portable anti-corrosive flow meters

Using Laminar Liquid Flow Devices

THE DEVICE IS ONLY CONFIGURED FOR ONE TYPE OF LIQUID, AND WILL ONLY FUNCTION PROPERLY WHEN USING THAT ONE LIQUID.

By default, liquid devices are configured only for use with pure water, such as distilled, de-ionized, Type I (Ultrapure), Type II, and Type III. If a device is used for any liquid other than the liquid it was specifically engineered for, readings will be incorrect

Minimize contaminants and liquid variations. For water devices, **DO NOT** use tap water or water with any biological components, minerals, or oils. Any of these substances will affect the viscosity of the liquid, leading to inaccurate flow measurements. More importantly, **these impurities will quickly build up in the laminar flow zone, cause corrosion, and degrade the measurement accuracy of the device.**

For support or questions regarding the use or operation of this device, please contact us using the information on [page 2](#).

Alicat offers countless combinations of device sizes, accessories, connections, and configurations. These custom solutions are offered to meet a variety of application challenges brought forth by users pushing the boundaries of our standard offerings.

If you have an idea for a new process or a challenging application, contact Alicat for specialized engineering and application support.

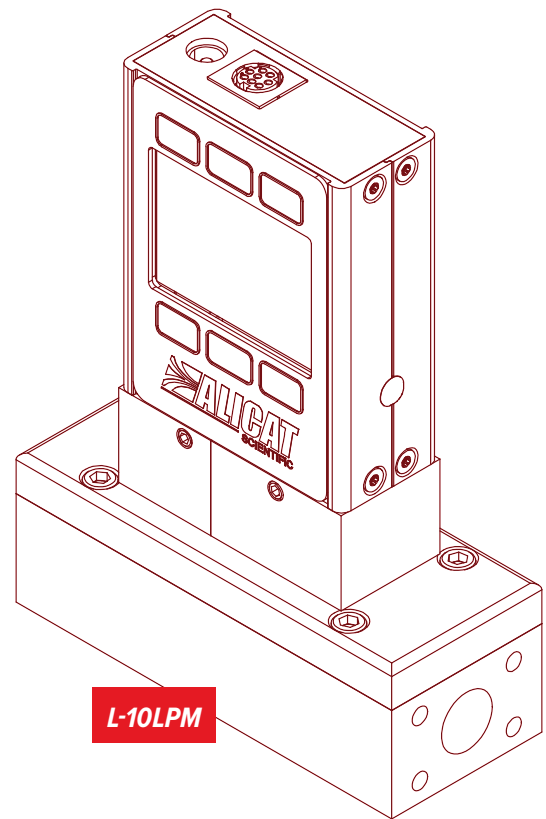

Contents

Introduction	3
Using Laminar Liquid Flow Devices.....	3
Quick Start Guide	5
Getting Started	6
Getting to Know Your Liquid Flow Meter	6
The Liquid Flow Meter Display.....	6
Status Messages.....	6
Mounting	6
Filters	6
Device Ports	7
Connecting Your Liquid Flow Meter	7
Operating Pressure.....	7
Bleed Ports.....	7
Power and Signal Connections	8
Analog Signals.....	9
Displaying Live Flow Data	10
Main Display	10
Taring Your Flow Meter	10
How to Tare.....	10
Option: Color TFT Display	10
Option: Collecting Totalized Flow Data	11
Device Information	11
Setup	12
Sensor Setup	12
Choosing Engineering Units.....	12
Flow and Pressure Averaging.....	12
Zero Band.....	12
Configuring Serial Communications	12
Unit ID.....	12
Modbus RTU Address.....	12
Baud Rate.....	12
Display Setup	13
Main Screen Options.....	13
Screen Lighting.....	13
Display Rotation.....	13
Advanced Setup	13
Serial Communication	14
Establishing Communication	14
Modbus RTU Communication	14
Serial Streaming vs Polling	14
Polling Mode.....	14
Taring	15
Collecting Flow Data	15
Quick Command Guide	16
Troubleshooting	17
Maintenance	18
Reference Information	19
Engineering Units	19
Pinouts	20
8-Pin Mini-DIN (Default).....	20
Locking Industrial Connector Pinout.....	20
9-Pin D-Sub Connector Pinouts.....	21

Quick Start Guide

Setup

- **Connect your liquid flow meter.** Ensure that flow will pass through your device in the same direction as the arrow on the flow body (usually left to right).
- **Choose your engineering units.** You can choose the measurement units by selecting **MAIN MENU** → **SETUP** → **Sensor** → **Engineering Units**, see [page 12](#) for more details.

Operation: Flow Verification

- **Monitor live volumetric flow, temperature, and pressure readings.** Readings are updated and displayed on your device in real time. See [page 10](#).
- (Optional) **Capture totalized readings.** The totalizer option displays the total flow that has passed through the device since the last time the totalizer was reset. If your device has a totalizer, press **NEXT** from the main live data display to access the totalizer. See [page 11](#).

Connectors and Buttons

The diagram the right below represents a typical configuration of a standard liquid flow meter. **Your liquid flow meter's appearance and connections may differ.**

Backlight

The monochrome display comes equipped with a backlight. **To toggle the backlight power, press the logo on the front of your device.**

For optional color TFT displays, pressing this button will turn off the display to conserve power. See [page 10](#).

Maintenance and Care

- Liquid flow meters require minimal cleaning when flowing clean liquids. Read more on [page 18](#).
- Calibrate your liquid flow meter annually. To schedule a calibration, please contact support ([page 2](#)).

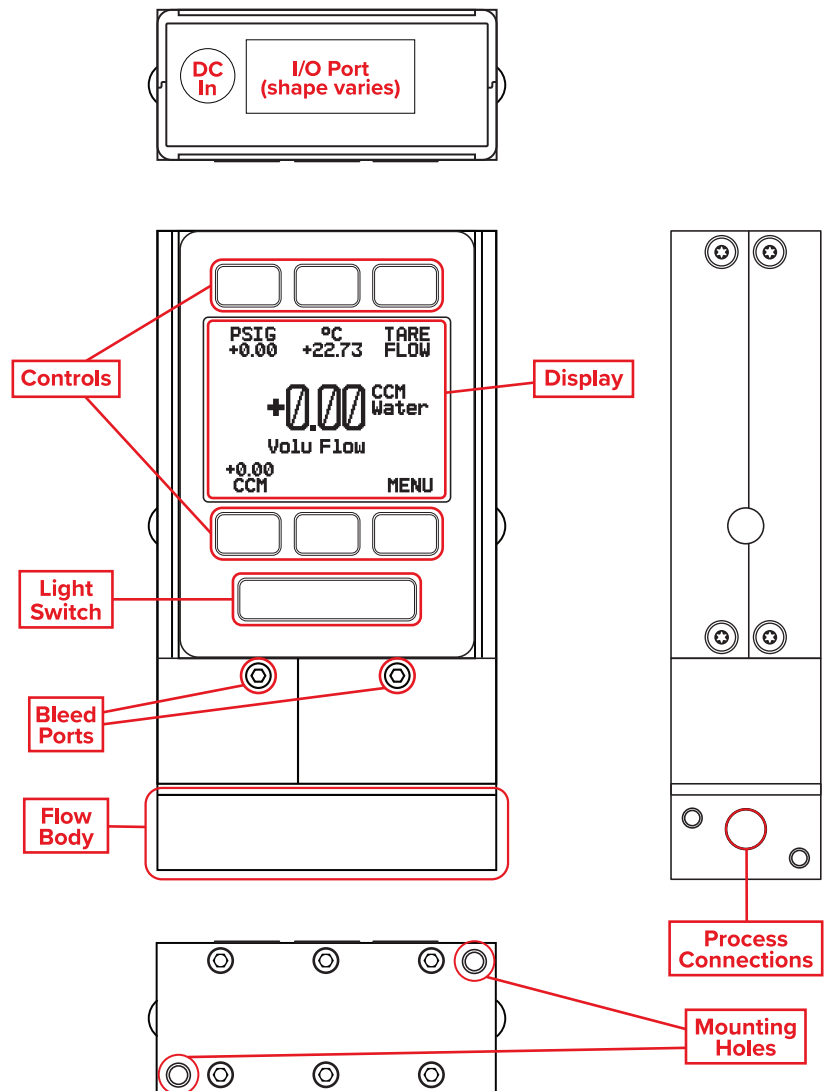

A typical liquid flow meter.

Getting Started

Getting to Know Your Liquid Flow Meter

The Liquid Flow Meter Display

The figure to the right identifies the various features of the flow meter display.

- 1 Highlights **pressure** in the center of the device.
- 2 Highlights **temperature** in the center of the device.
- 3 **Tares** the device's flow measurement ([page 10](#)).
- 4 Highlights **volumetric flow** rate in the center of the device.
- 6 **MENU** enters the **main menu** system.
NEXT accesses the optional **flow totalizer** ([page 11](#)).
- 7 Toggles the backlight.

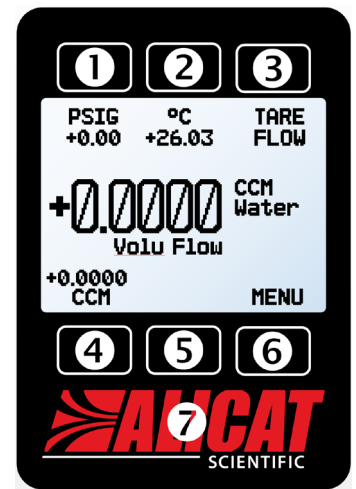

The *main display*. Note the button behind the logo, which toggles the device backlight.

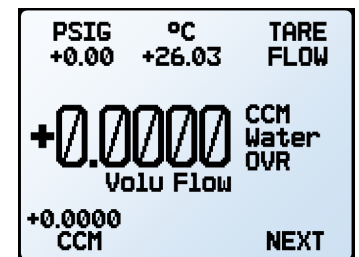

The *main display* with an **OVR** status message.

Status Messages

Status messages are shown to the right of the main readout number. In the example to the right, the **OVR** message shows that the totalizer rolled over to zero.

ADC Analog-digital converter error

POV Pressure over range of device

VOV Volumetric flow over range of device

LCK Front display is locked

TMF Totalizer missed out of range flow

OVR Totalizer rolled over to zero

TOV Temperature over range of device

Mounting

Liquid flow meters do not require straight runs of pipe are required upstream or downstream. Most flow meter models can be mounted in any position, including upside-down. All liquid flow meters use media-isolated sensors that must be tared after changing orientation.



Note: If air bubbles are continuously introduced to the flow upstream of the device, the device may be mounted up side-down to prevent bubbles from being trapped in the pressure sensor ports. Tare the device after changing its position or orientation.



Warning: If the device has been installed upside-down, avoid using the bleed screws as liquid may leak into the electronics housing and cause permanent damage that is not covered by the warranty.

Filters

When pressure drop is not a concern, use in-line sintered filters to prevent large particulates from entering the flow body of the meter. Suggested maximum particulate sizes are as follows:

- **20 microns** for units with flow ranges ≤ 100 CCM.
- **40 microns** for units with flow ranges > 100 CCM.



Note: Avoiding long runs of small-diameter tubing upstream or downstream of the device will reduce liquid hammer.

Device Ports

Your flow meter has been shipped with plastic plugs fitted into its ports. To lessen the chance of contaminating the flow stream, do not remove these plugs until you are ready to install the device.

Standard liquid flow meters have female inlet and outlet ports. VCR®-compatible and other specialty fittings may have male connections.

- If you are using a fitting that does not have a face seal, use thread-sealing Teflon tape to prevent leakage around the port threads, but **do not wrap the first two threads** entering the device. This will minimize the possibility of getting tape into the flow stream and clogging the laminar flow element.
- Face seal fittings do not need Teflon tape applied to the threads.



Warning: *It is not recommended to use pipe dopes or sealants on the process connections as these compounds can cause permanent damage to the meter should they get into the flow stream.*

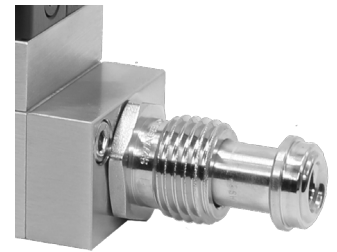

A VCR®-compatible connection.

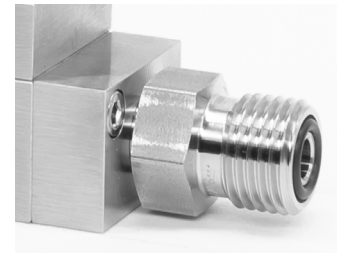

A VCO®-compatible connections.

Connecting Your Liquid Flow Meter

Your flow meter can measure flow generated by positive pressure and/or suction. Connect the meter so that the flow travels in the same direction as the flow arrow, usually from left to right from the front of the device.

Operating Pressure

Maximum operating line pressure is **100 PSIG**. If the line pressure is higher than 100 PSIG, use a pressure regulator upstream to reduce the pressure. Maximum proof pressure is 200 PSIG; above this pressure the device may be permanently damaged. Although the meter's operation is unidirectional, reversing the flow direction will not damage the device as long as the maximum specified limits are not exceeded.



Caution: *Exceeding the maximum specified line pressure may cause permanent damage to the solid-state differential pressure transducer.*

Bleed Ports

Liquid flow meters include bleed ports (8-32 Nylon tipped screw) on the front for the removal of air bubbles.

Bleed both of the ports as follows:

1. With the meter installed, gently loosen the upstream bleed port screw 1 to 2 turns, or until liquid begins to leak from the threads. **Do not remove the screw**, as it has pressure behind it, is very small, is easy to lose, and is delicate to rethread.
2. Gently tap the flow body to remove air bubbles (screwdriver handles work well). This may not be visible or audible.
3. Gently tighten the screw until the leakage stops, taking care not to crush the nylon tip.



Caution: *If your device is mounted in an inverted position, avoid using the bleed screws, as liquid may leak and cause permanent damage.*

5/64" 8-32 Nylon-tipped hex bleed screw

Loosen to bleed liquid, but do not remove

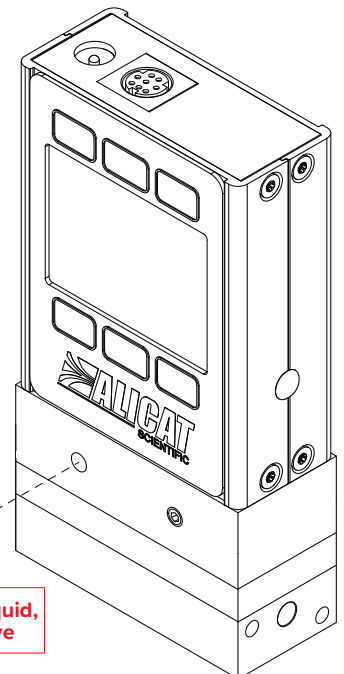

Option: Charging Your Portable Meter

Portable meters' batteries are partially charged before shipping. When fully charged, typical battery life is 18 hours with a monochrome display, or 8 hours with a TFT color display. Dimming the backlight will increase battery life. When the battery indicator displays it is completely empty, about 15 minutes of battery life remain.

Charge the device using the supplied USB cable (micro-B to type A) or a similar cable. Any USB outlet on a computer or portable power supply may be used, but charging will be fastest (approximately 3.5 hours) when connected to the supplied 2.0 A power supply.

The red indicator LED on top of the device lights up to indicate that the unit is charging, and turns off when the battery is charged.

Your meter may be used while it is charging. If the battery has been fully depleted, you may need to charge the device for a full minute before the device can be turned on.

Warning: The safe charging temperature range is 0–45°C (32–113°F). If internal sensors detect temperatures outside of this range, the battery will not charge.

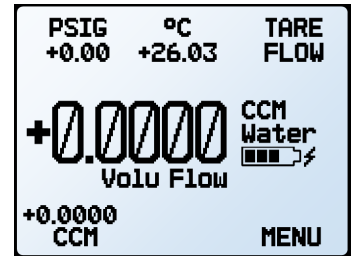

The *main display* with battery information and an active charging indicator (the lightning bolt).

Power and Signal Connections

Power can be supplied to your meter through either the power jack or the multi-pin connector on top of your device.

Note: Power requirements vary based on analog configuration. Please reference the associated specification sheet at alicat.com/specs for power requirements.

Standard 8-Pin Mini-DIN Pinout

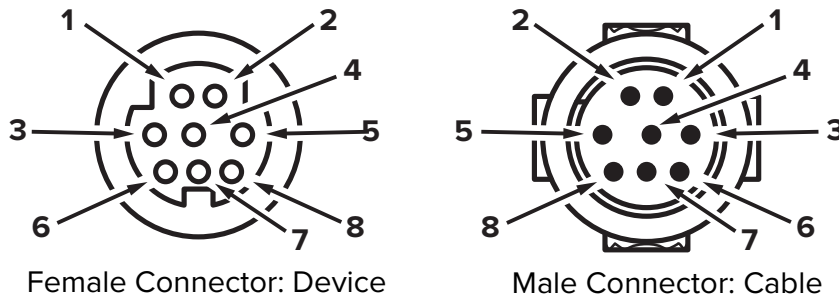

Pin	Function
1	Not Connected <i>Optional: 4–20 mA Primary Output Signal</i>
2	Static 5.12 Vdc by default. <i>Optional: Secondary Analog Output (4–20 mA, 0–5 Vdc, 1–5 Vdc, 0–10 Vdc) or Basic Alarm</i>
3	Serial RS-232 RX / RS-485(–) input signal (receive)
4	Remote tare (ground to tare)
5	Serial RS-232 TX / RS-485(+) output signal (send)
6	0–5 Vdc <i>Optional: 1–5 Vdc or 0–10 Vdc Output Signal</i>
7	Power In (as described above)
8	Ground (common for power, digital communications, analog signals and alarms)

The above pinout is applicable to all devices with the Mini-DIN connector. The availability of different output signals depends on the options ordered. Optional configurations are noted on the unit's calibration sheet.



Caution: Do not connect power to pins 1 through 6, as permanent damage can occur. It is common to mistake pin 2 (5.12 Vdc Output) as the standard 0–5 Vdc analog output signal. Pin 2 is normally a constant 5.12 Vdc.

For more pinout configurations, see [page 20](#).

Analog Signals

Primary Analog Output Signal

Most instruments include a primary analog output signal, which is linear over its entire range. For all analog output configurations, the lowest output indicates zero flow, and highest indicates full-scale flow. Depending on the quality of the grounding, a zero flow condition is approximately 0.010 Vdc.

For example, a 5 Vdc output from a 0–5 Vdc 100 CCM unit would indicate a flow of 100 CCM.

Using Ground to Tare

You can tare your meter remotely by momentarily grounding pin 4. When the switch is closed, the device will tare. Operation will resume when the switch is released. You can also tare with the front controls ([page 10](#)) or serial commands ([page 15](#)).

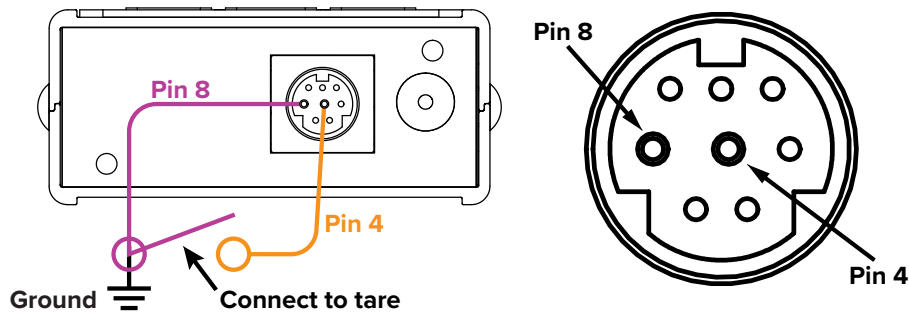

Option: Secondary Analog Output Signal

The default 8-pin Mini-DIN connector places the secondary analog output on pin 2 for both voltage and current signals. Your device's secondary analog signal may differ from its primary output signal.

The calibration sheet that shipped with the device shows which output signals were ordered.

Option: 4–20 mA Current Output Signal

If your meter has a 4–20 mA current primary or secondary output signal, your flow meter will require 15–30 Vdc power.



Caution: Do not connect 4–20 mA devices to “loop powered” systems, as this will damage portions of the circuitry beyond repair and void the warranty. If you must interface with existing loop powered systems, always use a signal isolator and a separate power supply.

Displaying Live Flow Data

Main Display

The **main display** has three primary functions:

- Displaying live temperature, pressure, and flow data
- Taring the flow meter (below)
- Accessing the **main menu (MENU)** or the optional totalizer (**NEXT**) ([page 11](#))

This screen displays live data for all flow parameters simultaneously. Live data is measured 1000 times per second and the LCD display is updated 10 times per second. The buttons next to the measurements highlight their values in the center.

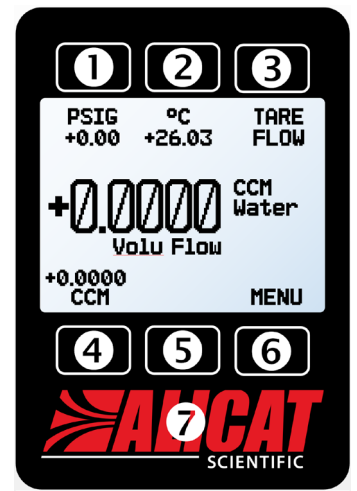

The main display.

Taring Your Flow Meter

MENU → **TARE FLOW** or **TARES**

Taring is an important practice that ensures your liquid flow meter is providing its most accurate measurements. This function gives the meter a zero reference for flow measurements. Gauge pressure can also be tared on all liquid devices.

How to Tare

Taring Flow

MENU → **TARES** → **TARE FLOW**

Flow tares should take place at the expected process pressure, with no flow. A message, “**ENSURE NO FLOW BEFORE PRESSING TARE**” will be displayed. Press **TARE** to complete the taring process.

Taring Pressure

MENU → **TARES** → **TARE PRESS**

After pressing **TARE PRESS**, the message, “**PRESS TARE WHEN VENTED TO AMBIENT WITH NO FLOW**”, followed by “**CURRENT PRESSURE OFFSET:**” will be displayed.

When to Tare

- Before every new flow measurement cycle
- After significant changes in temperature or pressure
- After dropping or bumping the flow controller
- After changing the device’s orientation

Option: Color TFT Display

Instruments ordered with a color display are functionally the same as standard backlit monochrome instruments. The color enables additional on-screen information.

Multi-Color Display Indicators

- **GREEN:** Parameter labels and adjustments associated with the button directly above or below the label.
- **WHITE:** Parameters operating under normal conditions.
- **RED:** Parameters with values exceeding 128% of the device’s specifications.
- **YELLOW:** Menu items ready to be selected. This color replaces the symbol (>) in selections on monochrome display.



Note: Press the logo to turn off the color display backlight. The flow meter remains in operation while the backlight is off.



Note: Color displays require an additional 40 mA when using a 12 Vdc power supply. All other device specifications from your device’s specification sheet remain in effect.

Option: Collecting Totalized Flow Data

MAIN DISPLAY → NEXT (totalizer menu)

The optional flow totalizer displays the total amount that has flowed through the instrument since its last reset, similar to a gasoline pump.

- **TOTAL/TIMER** toggles between totalized flow and elapsed time as the highlighted parameter in the center.
- **LPM** (or another measurement of volumetric flow) displays the live flow rate. Press to change engineering units ([page 12](#)).
- **V PEAK** displays the maximum flow rate since the last reset. Press to select engineering units ([page 12](#)).
- **RESET** clears all totalized data and immediately resets the timer to zero.
- **MENU** enters the main menu.

Totalizer Rollover Functions

The totalizer will report a maximum of 7 digits. By default, the placement of the decimal is the same as the live flow rate. The totalizer can be configured at the time of order for the following behaviors:

- **Rollover (Default):** Totalizer resumes counting from zero as soon as the maximum count has been reached.
- **Freeze:** Totalizer stops counting at max count, until it is reset manually.
- **Error (Default):** Displays **OVR** status message when maximum count has been reached; compatible with the rollover and freeze functions.

The elapsed time counter has a maximum value of 9999:59:59 (h:m:s) (416 days, 16 hours). If flow is still being totalized at that point, the timer freezes, regardless of the behavior chosen above for the totalized flow readings.

Device Information

The **ABOUT** menu (MENU → ABOUT) contains useful information for setup, configuration, and troubleshooting.

Basic Device Information

ABOUT → About Device

This includes information on the following:

- **MODEL:** Device model
- **SERIAL NO:** Serial number
- **DATE MFG:** Manufacturing date
- **DATE CAL:** Most-recent calibration date
- **CAL BY:** Initials of the person who calibrated the device
- **SW:** Firmware version
- **Display SW** (color displays only): Firmware version of the display

Device Full-Scale Ranges

ABOUT → Full Scale Ranges

This displays the maximum readable range of available flow and pressure readings. Most will include volumetric flow and gauge pressure. Devices equipped with an optional barometer will also show barometric pressures.

Manufacturer Information

ABOUT → About Manufacturer

About Manufacturer usually includes:

- Manufacturer name
- Web address
- Phone number
- Email address

Setup

Sensor Setup

MENU → SETUP → Sensor

Choosing Engineering Units

SETUP → Sensor → Engineering Units

Changing device engineering units alters both the display and the data frame. Choose the parameter whose unit you want to change, and then select your desired engineering unit, confirming the change on the last screen.

Flow and Pressure Averaging

SETUP → Sensor → Flow Averaging

SETUP → Sensor → Pressure Averaging

Averaging the flow over a longer time may be useful in smoothing fluctuating readings. This menu changes the time constants of the geometric running averages for flow and pressure. These are changed independently via **PRESS AVG** and **FLOW AVG** in the **averaging menu**, which also displays the current settings. Values roughly correspond to the time constant (in milliseconds) of the averaged values. Higher numbers generate a greater smoothing effect, to a maximum of 255 ms.

Zero Band

SETUP → Sensor → Zero Band

The zero band threshold is an amount of flow under which flow values are displayed as 0. The maximum zero band is 6.38%. For example, a 10-LPM meter with a zero band value of 0.25% would display as 0 LPM for all readings below 0.025 LPM.

Configuring Serial Communications

MENU → SETUP → RS-232 Serial or RS-485 Serial

You can operate the flow meter remotely via its data connection for easy streaming and logging of all data. Before connecting the flow meter to a computer, ensure that it is ready to communicate with your PC by checking the options in this menu. For more on how to issue commands from a computer, see [page 14](#).

Unit ID

SETUP → RS-232 Serial or RS-485 Serial → Unit ID

The unit ID is the identifier that a computer uses to distinguish your device from other, similar devices when it is connected to a network. Using the unit ID letters A–Z, you can connect up to 26 devices to a computer at the same time via a single COM port. This is called **polling mode** ([page 14](#)). Unit ID changes take effect when you select **SET**. If you select “0” as the unit ID, the flow meter will enter **streaming mode** when you exit the menu ([page 15](#)).

Modbus RTU Address

SETUP → RS-232 Serial or RS-485 Serial → Modbus Address

The Modbus address is the identifier that a computer or programmable logic controller (PLC) uses to distinguish your device from other devices when connected to a Modbus network. Values of 1–247 are available for use.

Baud Rate

SETUP → RS-232 Serial or RS-485 Serial → Baud Rate

Baud rate is the speed at which digital devices transfer information. The flow meter has a default baud rate of 19200 baud (bits per second). Your computer or software’s settings must match the flow meter’s baud rate. In the **BAUD menu**, ensure that they match. Alternatively, you can change your computer’s baud rate in Windows® Device Manager. Baud rate changes take effect once you press **SET**, but you may need to restart the software for it to recognize the change.

Display Setup

MENU → SETUP → Display

The options in the **display setup menu** adjust the contrast/brightness of the display and enable screen rotation.

Main Screen Options

SETUP → Display → MAIN Screen

Any Key Press changes what happens when any of the parameter buttons on the **main display** ([page 10](#)) are pressed (pressure or temperature, for example). By default, these buttons highlight their measurement in the center of the display. If this option is set to **Show Actions Menu**, an option to change that parameter's engineering units will be shown, as well as an option to highlight the parameter.

Screen Lighting

SETUP → Display → Screen Lighting

The options and wording in the **screen lighting menu** will vary for color displays.

- On monochrome displays, press **LESS CONTRAST** or **MORE CONTRAST** to adjust the contrast levels and move the contrast indicator left or right. **POWER UP Lit** or **Dark** toggles whether the backlight of the unit will be on when the device powers on.
- On color displays, press **DIMMER** or **BRIGHTER** to adjust the brightness level and move the brightness indicator left or right.

Display Rotation

SETUP → Display → Display Rotation

The device has the option of inverting (flipping) the screen, as configured in this menu.

Advanced Setup

MENU → SETUP → Advanced

The **advanced setup menu** contains settings and detailed information that are useful when troubleshooting with customer support.

Factory Restore

SETUP → Advanced → Factory Restore

This will immediately take you to a confirmation screen. When troubleshooting, an applications engineer may recommend doing a **Factory Restore**. If something is not acting as expected, please contact an applications engineer prior to doing a **Factory Restore**.

Register Status

SETUP → Advanced → Register Status

The **Register Status** screen displays live values for the internal device registers. Many of these values can help an applications engineer diagnose operational issues over the phone. Some register values clearly distinguish between hardware and operational problems, which speeds up the troubleshooting process.

Edit Register and Device Properties

SETUP → Advanced → Edit Register and SETUP → Advanced → Device Properties



Warning: *Editing these settings may cause the device to become inoperable. Do not modify them without working with customer support.*

Serial Communication

Connecting your device to a computer allows you to log the data that it generates. The device communicates digitally through its communications connector and cable using a real or virtual COM port on your computer. This section of the manual shows you how to operate the flow meter using ASCII commands.

Establishing Communication

After connecting your flow meter using a communications cable, you will need to establish serial communications through a real or virtual COM port on your computer or programmable logic controller (PLC).

- If you have connected your device to a serial port, note its COM port number, which can be found in the Windows® Device Manager program.
- If you have used a USB cable to connect your device to your computer, the computer in most cases will recognize your device as a virtual COM port. If it does not, download the appropriate USB device driver at alicat.com/drivers and note the COM port number as found in Windows® Device Manager.

The meter will be configured with the following settings:

- **Baud:** 19200 (by default; others can be used if the computer, software, and meter are all set to the same rate)
- **Data bits:** 8
- **Parity:** none
- **Stop bits:** 1
- **Flow control:** none

Alicat's Serial Terminal Application

Alicat's Serial Terminal is a preconfigured program for serial communications that functions much like the older Windows® HyperTerminal, with plain text in a command-line format.

Download Serial Terminal for free at alicat.com/drivers. Once downloaded, simply run SerialTerminal.exe. Enter the COM port number to which your device is connected and the baud rate of the flow meter. The default baud rate is 19200, but this is adjustable by entering the **RS-232 Serial1** menu on your flow meter ([page 12](#)).

Modbus RTU Communication

For details on Modbus commands, please visit alicat.com/manuals for the Modbus operating bulletin.

Serial Streaming vs Polling



Note: In what follows, **↵** indicates an ASCII carriage return (decimal 13, hexadecimal D). For many devices, this is the same as pressing the Enter key. Serial commands are not case-sensitive.

Polling Mode

Your device was shipped in polling mode with a unit ID of **A**, unless requested otherwise. Polling the device returns a single line of data each time you request it. To poll your device, simply enter its unit ID.

Poll the device: `[unit ID]↵`

Example: `a↵` (polls unit A)

You can change the unit ID of a polling device by typing:

Change the unit ID: `[current unit ID]@[desired unit ID]↵`

Example: `a@=b↵` (changes unit A to unit B)

You can also do this via the device's front panel menu ([page 10](#)). Valid unit IDs are letters A–Z, and up to 26 devices may be connected at any time, as long as each unit ID is unique.

Streaming Mode

In streaming mode, your device automatically sends a line of live data at regular intervals. Only one unit on a COM port may be in streaming mode at a time. To put your device into streaming mode, type:

Begin streaming: `[unit ID]@=@`

Example: `A@=@` (Begins streaming unit A)

This is equivalent to changing the unit ID to “@”. To take the flow meter out of streaming mode, assign it a unit ID by typing:

Stop streaming: `@@=[desired unit ID]`

Example: `@@=a` (stops and assigns unit ID of A)

When sending a command in streaming mode, the flow of data will not stop while the user is typing. This may make the commands you type unreadable. If the device does not receive a valid command, it will ignore it. If in doubt, simply hit `↵` and start again.

The default streaming interval is 50 ms, but this can be increased by changing Register 91 while the device is in polling mode:

Set streaming interval: `[unit ID]w91=[time in milliseconds]`

Example: `aw91=500` (streams new data every 500 ms)

Taring

Before collecting flow data, be sure to tare your meter.

Manual taring can be accomplished through two separate commands for flow and pressure. Taring flow sets the zero flow reading and must be done when no flow is passing through the flow meter:

Tare flow: `[unit ID]v`

Example: `av` (sets flow reading to zero)

Taring pressure sets the zero pressure reading and must be done when the device open to ambient pressure:

Tare gauge pressure: `[unit ID]p`

Example: `ap`

Collecting Flow Data

Collect live flow data by typing the `[unit ID]` command or by setting your flow meter to streaming. Each line of data for live flow measurements appears in the format below, but the unit ID is not present in streaming mode.

A	14.70	+24.57	+02.004	+02.004
ID	Gauge Pressure	Temperature	Volumetric Flow	Setpoint

Single spaces separate each parameter, and each value is displayed in the chosen device engineering units ([page 12](#)). You can query the engineering units of the serial data frame by typing:

Query live data info: `[unit ID]??d*`

Example: `a??d*` (returns the data frame descriptions)

Additional columns, including status codes ([page 6](#)), may be present after the last number. The unit ID appears in the data frame only when the flow meter is in polling mode.

Quick Command Guide

Change the unit ID: [unit ID]@[desired ID]↵
Tare flow: [unit ID]v↵
Tare gauge pressure: [unit ID]p↵
Poll the live data frame: [unit ID]↵
Begin streaming data: [unit ID]@=@↵
Stop streaming data: @@=[desired unit ID]↵
Set streaming interval: [unit ID]w91=[# of ms]↵
Query live data info: [unit ID]??d*↵
Manufacturer info: [unit ID]??m*↵
Firmware version: [unit ID]??m9↵ or ave↵
Lock the front display: [unit ID]l↵
Unlock the display: [unit ID]u↵



If you have need of more advanced serial communication commands, please download the serial primer at alicat.com/drivers.

Troubleshooting

If you run into trouble with installation or operation, get in touch with support ([page 2](#)).

General Use

Issue: *My device does not turn on, or has trouble staying on.*

Action: Check power and ground connections. Please reference the technical specifications to assure you have the proper power for your model.

Portable flow meters run on a rechargeable battery, but you can also connect to a wall outlet or computer using a micro-USB cable. If the battery has been fully depleted, it may take a minute or so to acquire enough charge to turn back on. If your flow meter will not power on after being plugged in for at least 5 minutes, contact support ([page 2](#)).

Issue: *The buttons do not work, and the screen shows LCK.*

Action: The flow meter buttons were locked out via a serial command ([unit ID]1←). Press and hold all four outer buttons to unlock the interface.

Issue: *I can't read the display easily.*

Action: During the day, you can increase the visibility of the display by increasing the contrast or brightness ([page 12](#)). For monochrome displays under low-light conditions, push the bottom central button (located below the display) to turn on the backlight.

Issue: *The analog output signal indicates values lower than what appears on my instrument's display.*

Action: Analog signal voltage degrades over long distances. You can minimize this effect by using wires with a heavier gauge, especially in the ground wire.

Issue: *How often do I need to calibrate my device?*

Action: Annual recalibrations are recommended. Check your device's last calibration date by selecting **MENU** → **ABOUT** → **About Device**. If it is time to recalibrate, request a recalibration from customer support ([page 2](#)).

Issue: *I dropped my device. Is it OK? Do I need to recalibrate?*

Action: If it turns on and appears to respond normally, then it is probably OK. It may or may not need a recalibration. Give it a tare, and compare it against a known-good flow standard. If it checks out, keep using it, but tell us about the drop at your next annual recalibration so we can check it out for you.

Issue: *How can I see readings in different units?*

Action: From the main menu, select **SETUP** → **Sensor** → **Engineering Units**. From this menu, you can adjust any variable's units. For more information, see ([page 12](#)).

Flow Readings

Issue: *The live flow readings won't settle down.*

Action: The device is very fast, so it can detect subtle variations in flow that may go unnoticed by your other devices. This sensitivity can help detect problems with pumps or flow controllers. You can lessen this sensitivity by increasing the flow averaging ([page 12](#)).

Issue: *My flow readings are negative.*

Action: Under conditions of no flow, a negative flow reading can indicate a poor tare. Ensure that the meter has no flow passing through it, and give it a fresh tare ([page 10](#)).

Issue: *My flow readings jump to zero when flow rates are low.*

Action: Your device is equipped with a programmable zero band that is preset at the factory. Reduce your deadband threshold ([page 12](#)).

Issue: *Does the meter work if it is laying down? Will it be accurate?*

Action: Yes to both, but the device should be tared after changing its orientation ([page 10](#)).

Issue: *Can I put the flow meter on top of a vibrating device? Will it be accurate?*

Action: Yes to both! The device is internally compensated for any changes in orientation; however, sensor noise will increase if the flow meter is vibrating.

Issue: *My meter does not agree with another liquid flow meter I have in line.*

Action: Liquid flow meters can normally be compared against one another provided there are no leaks between the two meters. One common cause of inaccuracy, inconsistency, or unusual readings is air bubbles trapped in one or both of the legs of the differential pressure sensor. Bleed the ports ([page 7](#)) to remove this possibility. Another possibility is that the liquid has some contaminant or additive, such as antifreeze, that affects the viscosity of the liquid. A third possibility is an improper tare error ([page](#)).

Issue: *My flow readings won't change when flow changes.*

Action: If your flow readings won't change regardless of actual flow, your flow sensor may be damaged. Please contact support to troubleshoot ([page 2](#)).

Issue: *Can I use the meter with other liquids?*

Action: No. Your flow meter is designed specifically to work with only one liquid, typically water. For use with a different liquid, the device will require recalibration. Please contact us to submit a service request at alicat.com/service.

Serial Communications

Issue: *I can't communicate to the device when it is connected to my PC.*

Action:

1. Make sure the baud rate your software and COM port require is the one your flow meter is using (**MENU → SETUP → RS-232 Serial or RS-485 Serial → Baud Rate**).
2. Check the flow meter unit ID (**MENU → SETUP → RS-232 Serial or RS-485 Serial → Unit ID**) to make sure you are addressing it properly with your serial commands.
3. Check the pinout (common pinouts are listed starting on [page 20](#)).
4. Make sure the COM number matches the one your software is using to connect to the flow meter.
5. On the external serial communications device (computer, PLC, etc.), be sure that the flow control (handshaking) settings are set as on [page 14](#).

Still experiencing issues? Please contact support ([page 2](#)).

Maintenance

Cleaning

This device requires minimal maintenance. If necessary, the outside of the device can be cleaned with a soft dry cloth. Avoid excess moisture or solvents. The primary cause of damage and/or long-term inaccuracy in these devices is contamination and/or corrosion damage. Liquid should be filtered for particulates or biological materials that may grow in the device ([page 6](#)). When removing these units from the line for any extended period of time, make an effort to remove all of the liquid from the device, as deposits of calcium or other soluble minerals can affect the accuracy of the device.



Caution: *If you suspect that debris or other foreign material has entered your device, do not take apart the flow body to clean it, as this will negate its NIST-traceable calibration. Please contact support for cleaning ([page 2](#)).*

Recalibration

The recommended period for recalibration is once every year. A label located on the back of the device lists the most recent calibration date. This date is also stored inside your flow meter and is visible by selecting **MENU → ABOUT → About Device**.

When it is time for your device's annual recalibration, contact support ([page 2](#)) with your device's serial number and your contact information.

Reference Information

Engineering Units

For more information on engineering units, see (page 12). Not all units are available on all devices.

Flow Units

Label	Notes
μL/m	MicroLiter per minute*
mL/s	MilliLiter per second
mL/m	MilliLiter per minute
mL/h	MilliLiter per hour
L/s	Liter per second
LPM	Liter per minute
L/h	Liter per hour
US GPM	US gallon per minute
US GPH	US gallon per hour
CCS	Cubic centimeter per second
CCM	Cubic centimeter per minute
cm ³ /h	Cubic centimeter per hour [†]
m ³ /m	Cubic meter per minute [†]
m ³ /h	Cubic meter per hour [†]
m ³ /d	Cubic meter per day [†]
in ³ /m	Cubic inch per minute [†]
CFM	Cubic foot per minute
CFH	Cubic foot per hour
CFD	Cubic foot per day
count	Setpoint count, 0–64000
%	Percent of full scale

Total Units

Label	Notes
μL	MicroLiter [‡]
mL	MilliLiter
L	Liter
US GAL	US gallon
cm ³	Cubic centimeter [†]
m ³	Cubic meter [†]
in ³	Cubic inch [†]
ft ³	Cubic foot [†]
μP	Micropoise, a measure of viscosity*
mg	Milligrams
g	Grams
kg	Kilograms
oz	US ounces
lb	US pounds

Time Units

Label	Notes
h:m:s	Hours:minutes:seconds
ms	Milliseconds
s	Seconds
m	Minutes
hour	Hours
day	Days

Temperature Units

Label	Notes
°C	degrees Celsius
°F	degrees Fahrenheit
K	Kelvin
°R	degrees Rankine

True Mass Flow Units

Label	Notes
mg/s	Milligram per second
mg/m	Milligram per minute
g/s	Gram per second
g/m	Gram per minute
g/h	Gram per hour
kg/m	Kilogram per minute
kg/h	Kilogram per hour
oz/s	Ounce per second
oz/m	Ounce per minute
lb/m	Pound per minute
lb/h	Pound per hour

Pressure Units

Label	Notes
PaG	Pascal
hPaG	Hectopascal
kPaG	Kilopascal
MPaG	Megapascal
mbarG	Millibar
barG	Bar
g/cm ² G	Gram force per square centimeter [†]
kg/cm ² G	Kilogram force per square centimeter [†]
PSIG	Pound force per square inch
PSFG	Pound force per square foot
mTorrG	Millitorr
torrG	Torr
mmHgG	Millimeter of mercury at 0°C
inHgG	Inch of mercury at 0°C
mmH ₂ OG	Millimeter of water at 4°C (NIST conventional) [†]
mmH ₂ OG	Millimeter of water at 60°C [†]
cmH ₂ OG	Centimeter of water at 4°C (NIST conventional) [†]
cmH ₂ OG	Centimeter of water at 60°C [†]
inH ₂ OG	Inch of water at 4°C (NIST conventional) [†]
inH ₂ OG	Inch of water at 60°C [†]
atm	Atmosphere
count	Count, 0–64000
%	Percent of full scale

* Displayed as kg/cmG.

[†] Superscript and subscript numerals are displayed as lining (normal) numerals.

[‡] Instances of μ are displayed as a lower-case u.

Pinouts

Check the calibration data sheet and pinout for your device. See [page 14](#) for additional important information about connecting your device to a computer for serial commands. Individual pinouts available at alicat.com/pinout.

8-Pin Mini-DIN (Default)

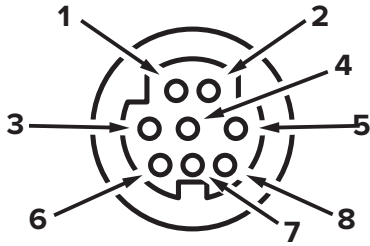

Female Connector: Device

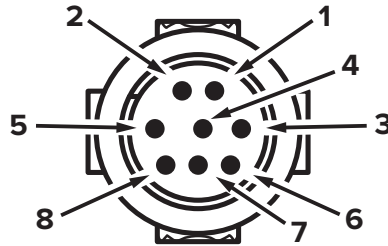

Male Connector: Cable

Pin	Function
1	Not connected <i>Optional: 4–20 mA primary output signal</i>
2	Static 5.12 Vdc <i>Optional: Secondary analog output (4–20 mA, 0–5 Vdc, 1–5 Vdc, 0–10 Vdc) or basic alarm</i>
3	Serial RS-232RX input signal <i>Optional: RS-485 A</i>
4	Remote tare (ground to tare)
5	Serial RS-232TX output signal <i>Optional: RS-485 B</i>
6	0–5 Vdc <i>Optional: 1–5 Vdc or 0–10 Vdc) output signal</i>
7	Power In
8	Ground (common for power, digital communications, analog signals, and alarms)



Caution: Do not connect power to pins 1 through 6, as permanent damage can occur. It is common to mistake pin 2 (labeled 5.12 Vdc Output) as the standard 0–5 Vdc analog output signal. Pin 2 is normally a constant 5.12 Vdc.

Locking Industrial Connector Pinout

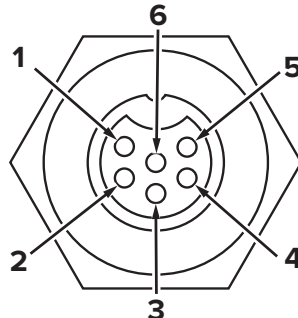
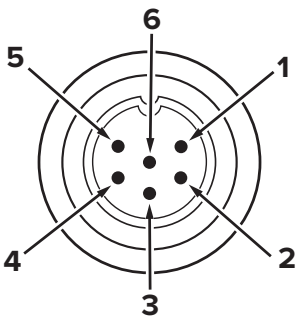

Pin	Function
1	Power In (+)
2	RS-232TX / RS-485 B
3	RS-232RX / RS-485 A
4	Remote tare (ground to tare)
5	Ground (common for power, communications, and signals)
6	Signal Out (voltage or current as ordered)



Note: The availability of different output signals depend on the options ordered.

9-Pin D-Sub Connector Pinouts

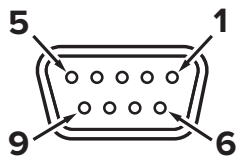

Female Connector

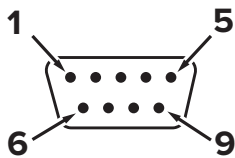

Male Connector

DB9 (Female)					
Pin	DB9M (Male)	DB9A / DB9K	DB9R	DB9T	DB9U
1	Current Out	NC	TX or B	TX or B	RX or A
2	Analog Out 2	Analog Out	Analog Out	Analog Out	Analog Out
3	RX or A	Power In	Analog In	Power In	Power In
4	Analog In	Ground	Ground	Ground	Ground
5	TX or B	TX or B	NC	NC	NC
6	Analog Out	Analog In	RX or A	Analog In	Analog In
7	Power In	Ground	Power In	Ground	Ground
8	Ground	Ground	Ground	Ground	Ground
9	Ground	RX or A	Ground	RX or A	TX or B

Pin	DB9B	DB9G	DB9H	DB9I	DB9N
1	Analog Out 2	RX or A	TX or B	NC	Power In
2	Analog Out	Analog Out	Analog Out	Analog Out	Analog In
3	Power In	Ground	Analog In	Power In	Analog Out
4	Ground	Power In	RX or A	Ground	NC
5	Ground	Ground	Analog Out 2	NC	Ground
6	Analog In	TX or B	NC	Analog In	Ground
7	Ground	Analog In	Power In	Ground	RX or A
8	TX or B	Current Out	Ground	RX or A	TX or B
9	RX or A	Ground	Ground	TX or B	NC5

Key of Terms:

Current Out Not Connected

Analog In Analog Setpoint Input

Analog Out 0–5 Vdc Output Signal
(1–5, 0–10 Vdc optional)

Analog Out 2 5.12 Vdc or Optional
Secondary Analog Output

TX or B Serial RS-232TX or RS-485 B

RX or A Serial RS-232RX or RS-485 A

NC Not Connected

Power In (+Vdc)

Ground Common for power, digital commu-
nications, analog signals, and alarms

15-Pin D-Sub Connector Pinouts

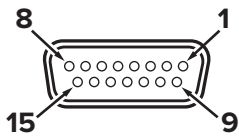

Female Connector: Cable

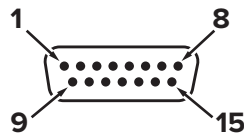

Male Connector: Device

Pin	DB15	DB15A	DB15B	DB15H	DB15K	DB15O	DB15S
1	Ground	Ground	Ground	NC	NC	Ground	Ground
2	Analog Out	Analog Out	Analog Out	RX or A	Analog Out	NC	Analog Out
3	Ground	Analog In	NC	NC	NC	NC	NC
4	NC	Ground	NC	NC	NC	Analog Out	NC
5	Power In	Ground	Power In	Ground	Ground	Power In	Ground
6	NC	Ground	NC	Analog Out	NC	NC	NC
7	NC	Power In	NC	Ground	Power In	Analog In	NC
8	Analog In	TX or B	Analog In	NC	Analog In	NC5	Analog In
9	Ground	Ground	Ground	NC	Analog Out 2	Ground	Ground
10	Ground	NC	Ground	Analog Out 2	NC	Ground	Ground
11	Analog Out 2	NC	Analog Out 2	Power In	Ground	Analog Out 2	Analog Out 2
12	NC	Analog Out 2	NC	Ground	Ground	NC	RX or A
13	RX or A	NC	NC	NC	RX or A	NC	Power In
14	Ground	NC	RX or A	Analog In	TX or B	RX or A	TX or B
15	TX or B	RX or A	TX or B	TX or B	Ground	TX or B	Ground

M12 Connector Pinouts

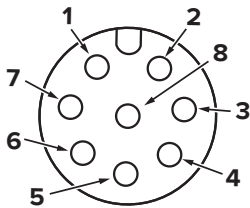

Female Connector: Cable

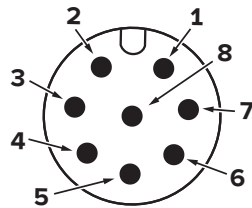

Male Connector: Device

Pin	M12	M12MD
1	0–5 Vdc output signal <i>Optional: 1–5 or 0–10 Vdc</i>	Not connected <i>Optional: 4–20 mA primary output signal</i>
2	Power in	Static 5.12 Vdc <i>Optional: Secondary analog output (4–20 mA, 0–5 Vdc, 1–5 Vdc, 0–10 Vdc) or basic alarm</i>
3	Serial RS-232 RX signal <i>Optional: RS-485 A</i>	Serial RS-232 RX signal <i>Optional: RS-485 A</i>
4	Analog Setpoint Input	Analog Setpoint Input
5	Serial RS-232 TX signal <i>Optional: RS-485 B</i>	Serial RS-232 TX signal <i>Optional: RS-485 B</i>
6	Static 5.12 Vdc <i>Optional: Secondary analog output (4–20 mA, 0–5 Vdc, 1–5 Vdc, 0–10 Vdc) or basic alarm</i>	0–5 Vdc Output Signal <i>Optional: 1–5 or 0–10 Vdc</i>
7	Ground (common for power, digital communications, analog signals, and alarms)	Power in
8	Inactive <i>Optional: 4–20 mA primary output signal</i>	Ground (common for power, digital communications, analog signals, and alarms)

Key of Terms:

Current Out

Not Connected

Analog In

Analog Setpoint Input

Analog Out

0–5 Vdc Output Signal (1–5, 0–10 Vdc optional)

Analog Out 2

5.12 Vdc or Optional Secondary Analog Output

TX or B

Serial RS-232TX or RS-485 B

RX or A

Serial RS-232RX or RS-485 A

NC Not Connected

Power In (+Vdc)

Ground

Common for power, digital communications, analog signals, and alarms





Contact Information

World Headquarters, Tucson, Arizona, USA

info@alicat.com

alicat.com

7641 N Business Park Dr.,

Tucson, AZ 85743 USA

+1 888-290-6060

Europe

europe@alicat.com

Geograaf 24

6921 EW Duiven

The Netherlands

+31 (0)26 203.1651

India

india@alicat.com

Halma India Pvt. Ltd.

Plot No . A-147, Road No. 24,

Next to Spraytech Circle

opp. Metropolitan Company, Wagle Industrial Estate

Thane-West

Mahārāshtra 400 604

+91 022-41248010

China & SE Asia

info-cn@alicat.com

alicat.com.cn

2nd Floor, Block 63, No. 421,

Hong Cao Rd,

Shanghai 200233

PRC

+86-21-60407398 ext. 801

For devices ordered with CSA, ATEX, ISO 17025, or other certifications, visit alicat.com/certifications for more information.

For information about our limited lifetime warranty, visit alicat.com/warranty.