

TOP VALVE BILL OF MATERIAL (P/N: 125 2 6 03TLP)						
NO.	NAME OF PART	QTY.	MATERIAL	PART NO.	SPECIFICATION	DWG. NO.
1	BODY, VALVE SUB-ASSEMBLY	1	316SS	V21741 T		V-21741
2	STEM	1	316SS	V18837 TL2	A276 OR A479	V-18837
3	WASHER, VALVE SEAL	1	TEFLON	V18844		V-18844
4	WASHER, STEM PACKING	1	316SS	X174282		V-21748
5	PACKING, STEM	1	GRAPHITE	V18843		V-18843
6	NUT, STEM PACKING	1	316/316LSS	V18840 T		V-18840
7	STOP, BALL CHECK	1	410SS	X177300		V-21748
8	BALL CHECK	1	316SS	V18852		V-21748
9	HANDWHEEL	1	ALUMINUM	V18851		V-21748
10	TAG	1	304SS	V18877		V-18877
11	NUT, STEM	1	CARBON STEEL	X171292		V-21748
12	WASHER	1	316SS	V18863 2 T		V-21739
13	PACKING	1	EPDM	V18848 1		V-21737
14	GLAND	1	316/316LSS	V18838 TL2	A479	V-18838
15	NUT, GLASS PACKING	1	316/316LSS	V18841 T2	QQ-S-763	V-18841
16	PLUG	1	316SS	P772 T1		P-772

BOTTOM VALVE BILL OF MATERIAL (P/N: 125 2 6 04TLP)						
NO.	NAME OF PART	QTY.	MATERIAL	PART NO.	SPECIFICATION	DWG. NO.
1	BODY, VALVE	1	316SS	V21741 T		V-21741
2	STEM	1	316SS	V18837 TL2	A276 OR A479	V-18837
3	WASHER, VALVE SEAL	1	TEFLON	V18844		V-18844
4	WASHER, STEM PACKING	1	316SS	X174282		V-21748
5	PACKING, STEM	1	GRAPHITE	V18843		V-18843
6	NUT, STEM PACKING	1	316/316LSS	V18840 T		V-18840
7	STOP, BALL CHECK	1	410SS	X177300		V-21748
8	BALL CHECK	1	316SS	V18852		V-21748
9	HANDWHEEL	1	ALUMINUM	V18851		V-21748
10	TAG	1	304SS	V18877		V-18877
11	NUT, STEM	1	CARBON STEEL	X171292		V-21748
12	WASHER	1	304SS	V13936 R		V-13936
13	PACKING	1	EPDM	V18848 1		V-21737
14	GLAND	1	316/316LSS	V18838 TL2	A479	V-18838
15	NUT, GLASS PACKING	1	316/316LSS	V18841 T2	QQ-S-763	V-18841
16	PLUG	1	316SS	P772 T1		P-772

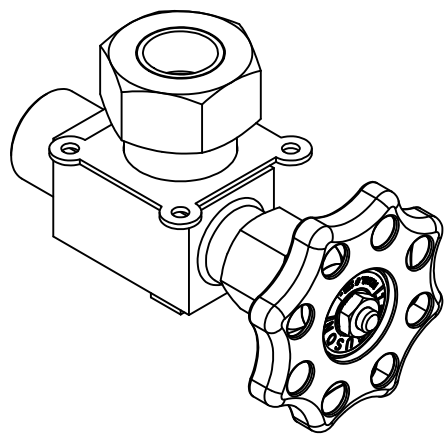

NOTES:  
 1. DIMENSIONS IN INCHES W/ mm EQUIVALENTS IN BRACKETS.  
 2. VALVE RATING VARIES WITH TEMPERATURE AND GLASS LENGTH.  
 3. FOR PACKAGING, REFER TO BOX DRAWING V-21775.

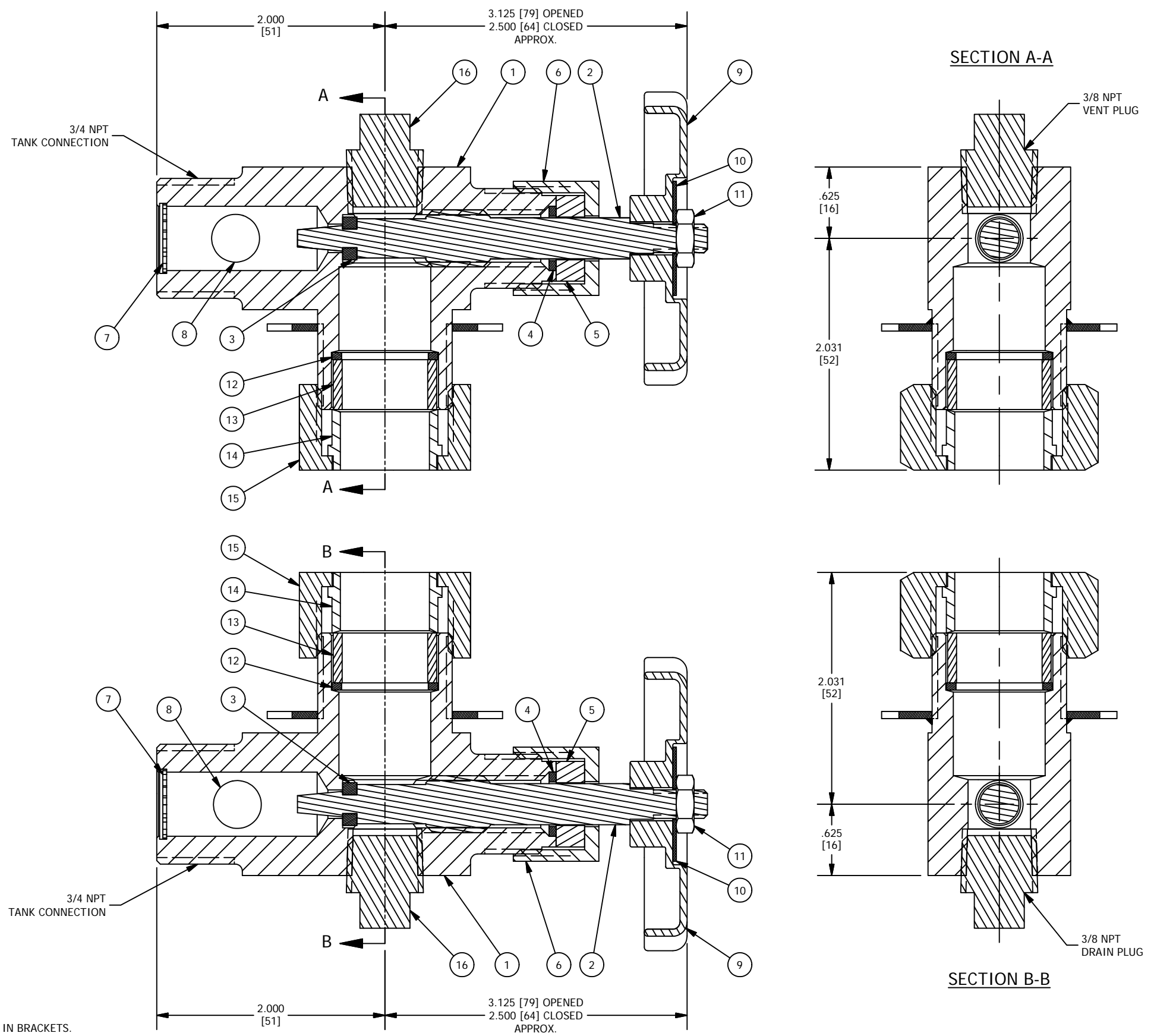

MANUFACTURED BY  
**Clark-Reliance®**  
 16633 FOLTZ PARKWAY  
 STRONGSVILLE, OH 44149 USA  
 (440) 572-1500 | www.clarkreliance.com  
 © Clark-Reliance® Corporation. All Rights Reserved.

**JERGUSON®**  
 125 VALVE SET (316SS)  
 3/4" MNPT X 3/4" OD X 3/8" FNPT

DRAWN:	SSF
CHECKED:	MK
DATE:	2/20/2014
REVISION:	0
DRAWING NO.:	125-2-6-03/04TLP
REV.:	0