

| BILL OF MATERIAL (CS BODY/416SS TRIM) | | | | | BILL OF MATERIAL (316SS BODY/316SS TRIM) | | | | | BILL OF MATERIAL (ALL 316SS) | | | | | | | |
|---------------------------------------|-----------------------|------|---------------------|------------|--|-----|-----------------------|------|---------------------|------------------------------|--------------------|-----|-----------------------|------|---------------------|------------|--------------------|
| NO. | NAME OF PART | QTY. | MATERIAL | PART NO. | SPECIFICATION | NO. | NAME OF PART | QTY. | MATERIAL | PART NO. | SPECIFICATION | NO. | NAME OF PART | QTY. | MATERIAL | PART NO. | SPECIFICATION |
| 1 | BODY, BOTTOM VALVE | 1 | CARBON STEEL | PER ORDER | A105 | 1 | BODY, BOTTOM VALVE | 1 | 316/316LSS | PER ORDER | A182 GR.F316/F316L | 1 | BODY, BOTTOM VALVE | 1 | 316/316LSS | PER ORDER | A182 GR.F316/F316L |
| 2 | STEM | 1 | 416SS | V11955 U3 | QQ-S-763 | 2 | STEM | 1 | 316/316LSS | V11955 TL2 | A479 | 2 | STEM | 1 | 316/316LSS | V11955 TL2 | A479 |
| 3 | TAILPIECE, TANK CONN. | 1 | LOW TEMP CS | PER ORDER | A350 GR.LF2 | 3 | TAILPIECE, TANK CONN. | 1 | 316/316LSS* | PER ORDER | | 3 | TAILPIECE, TANK CONN. | 1 | 316/316LSS* | PER ORDER | |
| 4 | NUT, TAILPIECE | 1 | LOW TEMP CS | PER ORDER | A350 GR.LF2 | 4 | NUT, TAILPIECE | 1 | LOW TEMP CS | PER ORDER | A350 GR.LF2 | 4 | NUT, TAILPIECE | 1 | 316/316LSS | PER ORDER | A276 GR.F316/F316L |
| 5 | PACKING RING | 1 | LOW TEMP CS | P254 1 A32 | A350 GR.LF2 | 5 | PACKING RING | 1 | 316/316LSS | P254 1 T2 | A479 | 5 | PACKING RING | 1 | 316/316LSS | P254 1 T2 | A479 |
| 6 | PACKING | 3 | CARBON YARN/INCONEL | G259 | | 6 | PACKING | 3 | CARBON YARN/INCONEL | G259 | | 6 | PACKING | 3 | CARBON YARN/INCONEL | G259 | |
| 7 | GLAND | 1 | LOW TEMP CS | V10167 A32 | A350 GR.LF2 | 7 | GLAND | 1 | LOW TEMP CS | V10167 A32 | A350 GR.LF2 | 7 | GLAND | 1 | 316/316LSS | V10167 T2 | |
| 8 | NUT, GLAND | 1 | LOW TEMP CS | P70 6 A32 | A350 GR.LF2 | 8 | NUT, GLAND | 1 | LOW TEMP CS | P70 6 A32 | A350 GR.LF2 | 8 | NUT, GLAND | 1 | 316/316LSS | P70 6 T2 | A276 GR.F316/F316L |
| 9 | BALL CHECK | 1 | 440SS | P1 1 | | 9 | BALL CHECK | 1 | 316SS | P1 T2 | QQ-S-763 | 9 | BALL CHECK | 1 | 316SS | P1 T2 | QQ-S-763 |
| 10 | STOP, BALL CHECK | 1 | 316SS | V13113 T | | 10 | STOP, BALL CHECK | 1 | 316SS | V13113 T | | 10 | STOP, BALL CHECK | 1 | 316SS | V13113 T | |
| 11 | HANDWHEEL | 1 | CARBON STEEL | PD325 D1 | | 11 | HANDWHEEL | 1 | CARBON STEEL | PD325 D1 | | 11 | HANDWHEEL | 1 | CARBON STEEL | PD325 D1 | |
| 12 | NUT, STEM | 1 | CARBON STEEL | P78 6 A12 | A563 | 12 | NUT, STEM | 1 | CARBON STEEL | P78 6 A12 | A563 | 12 | NUT, STEM | 1 | 316SS | P78 6 T | |
| 13 | TAILPIECE, GAGE CONN. | 1 | LOW TEMP CS | PER ORDER | A350 GR.LF2 | 13 | TAILPIECE, GAGE CONN. | 1 | 316/316LSS* | PER ORDER | | 13 | TAILPIECE, GAGE CONN. | 1 | 316/316LSS* | PER ORDER | |
| 14 | NUT, TAILPIECE | 1 | LOW TEMP CS | PER ORDER | A350 GR.LF2 | 14 | NUT, TAILPIECE | 1 | LOW TEMP CS | PER ORDER | A350 GR.LF2 | 14 | NUT, TAILPIECE | 1 | 316/316LSS | PER ORDER | A276 GR.F316/F316L |
| 15 | RATING TAG | 1 | 304SS | V22038 2 | | 15 | RATING TAG | 1 | 304SS | V22038 2 | | 15 | RATING TAG | 1 | 304SS | V22038 2 | |

*17-4PHSS FOR SPHERICAL TAILPIECES

*17-4PHSS FOR SPHERICAL TAILPIECES

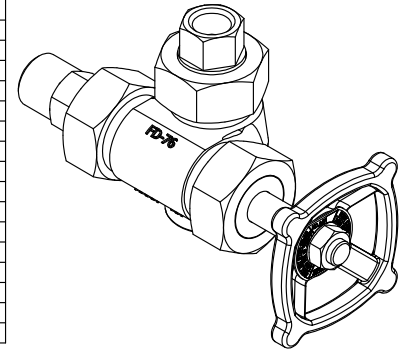

- NOTES:
- DIMENSIONS IN INCHES W/ mm EQUIVALENTS IN BRACKETS
 - TOP AND BOTTOM VALVES SAME EXCEPT OPPOSITE HANDING (I.E., MIRROR IMAGES) (BOTTOM LEFT HAND VALVE SHOWN)
 - VALVE RATING - CARBON STEEL & 316SS:
2400 PSI @ 100°F, 1323 PSI @ 800°F
(169 KG/CM² @ 38°C, 93 KG/CM² @ 427°C)
 - SEE TABLES FOR AVAILABLE STANDARD CONNECTIONS
 - REFER TO THE FOLLOWING (FOR):
 - CATALOG BULLETIN J100.50 (ADDITIONAL INFORMATION)
 - IOM BULLETIN J500.07 (INSTRUCTIONS)
 - VALVE "TRIM" = STEM & BALL CHECK
 - CONSULT FACTORY FOR ALTERNATE MATERIAL OPTIONS

| UNION TANK CONNECTION ("A" DIMENSION) | | | | | | | | | |
|---------------------------------------|--------------------|-------------------------|-------------------------|------------|-------------|------------|-------------------------|------------------|--|
| 1/2" MNPT (OR MSW) | 1/2" FNPT (OR FSW) | 1/2" MNPT SPH. (OR MSW) | 1/2" FNPT SPH. (OR FSW) | 3/4" MNPT | 3/4" MSW | 3/4" FNPT | 3/4" MNPT SPH. (OR MSW) | 1" MNPT (OR MSW) | |
| 3.688 [94] | 2.813 [71] | 4.313 [110] | 3.438 [87] | 3.688 [94] | 4.500 [114] | 2.813 [71] | 4.313 [110] | 4.125 [105] | |

| UNION GAGE CONNECTION ("B" DIMENSION) | | | | | | | | | |
|---------------------------------------|--------------------|-------------------------|-------------------------|------------|------------|------------|-------------------------|------------------|--|
| 1/2" MNPT (OR MSW) | 1/2" FNPT (OR FSW) | 1/2" MNPT SPH. (OR MSW) | 1/2" FNPT SPH. (OR FSW) | 3/4" MNPT | 3/4" MSW | 3/4" FNPT | 3/4" MNPT SPH. (OR MSW) | 1" MNPT (OR MSW) | |
| 3.563 [91] | 2.688 [68] | 4.188 [106] | 3.313 [84] | 3.563 [91] | 3.563 [91] | 2.688 [68] | 4.188 [106] | 4.000 [102] | |

| VENT / DRAIN CONNECTION | |
|---------------------------------|--|
| 1/2" OR 3/4" FNPT (OR FSW) ONLY | |

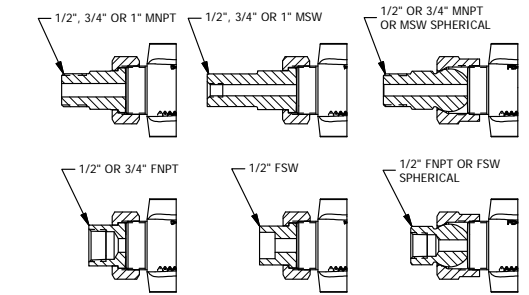
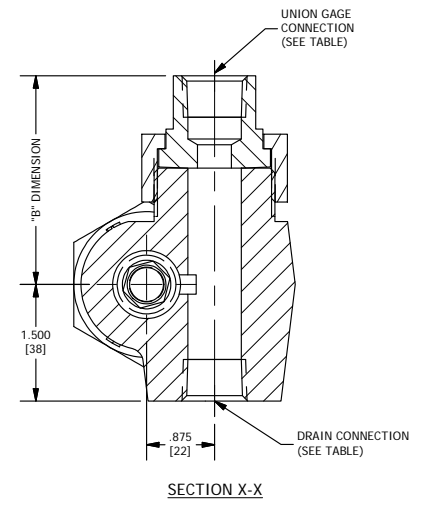
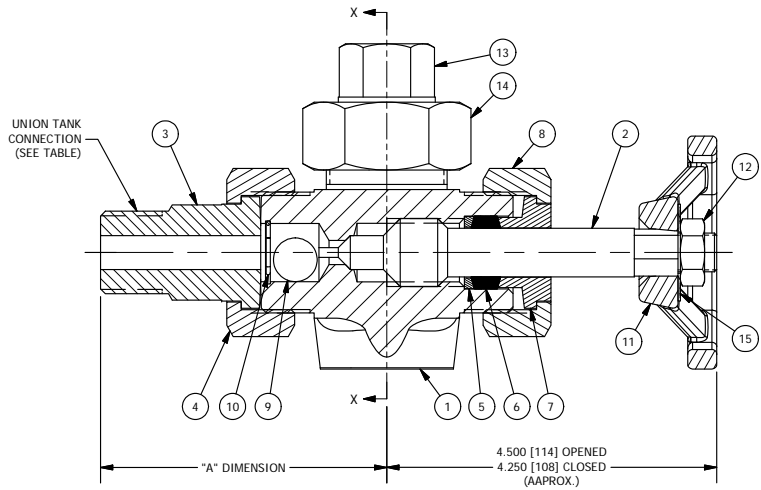

TANK & GAGE CONNECTION
(3/4" FSW UNION CONNECTION NOT AVAILABLE AS STANDARD)

| | | | |
|-----|------------|---|-----|
| 2 | 10/25/2019 | CHANGED PACKING MATERIAL FROM GRAPHITE/NICR | JJK |
| 1 | 2/22/2018 | UPDATE BOM | JLI |
| REV | DATE | REVISION | BY |

MANUFACTURED BY
Clark-Reliance®
 16633 FOLTZ PARKWAY
 STRONGSVILLE, OH 44149 USA
 (440) 572-1500 | www.clarkreliance.com
 © Clark-Reliance® Corporation. All Rights Reserved.

JERGUSON®
 #147 OFFSET VALVE (PLAIN-CLOSING)
 UNION TANK & GAGE CONNECTIONS

| | |
|------------------|---------|
| DRAWN: DDenk | REV.: 2 |
| CHECKED: MK | |
| DATE: 7/8/2013 | |
| REVISION: 2 | |
| DRAWING NO.: 147 | |